

**FORMAT 4**®

**profit H350R**  
FIVE AXES FOR  
UNIVERSAL CRAFTSMEN

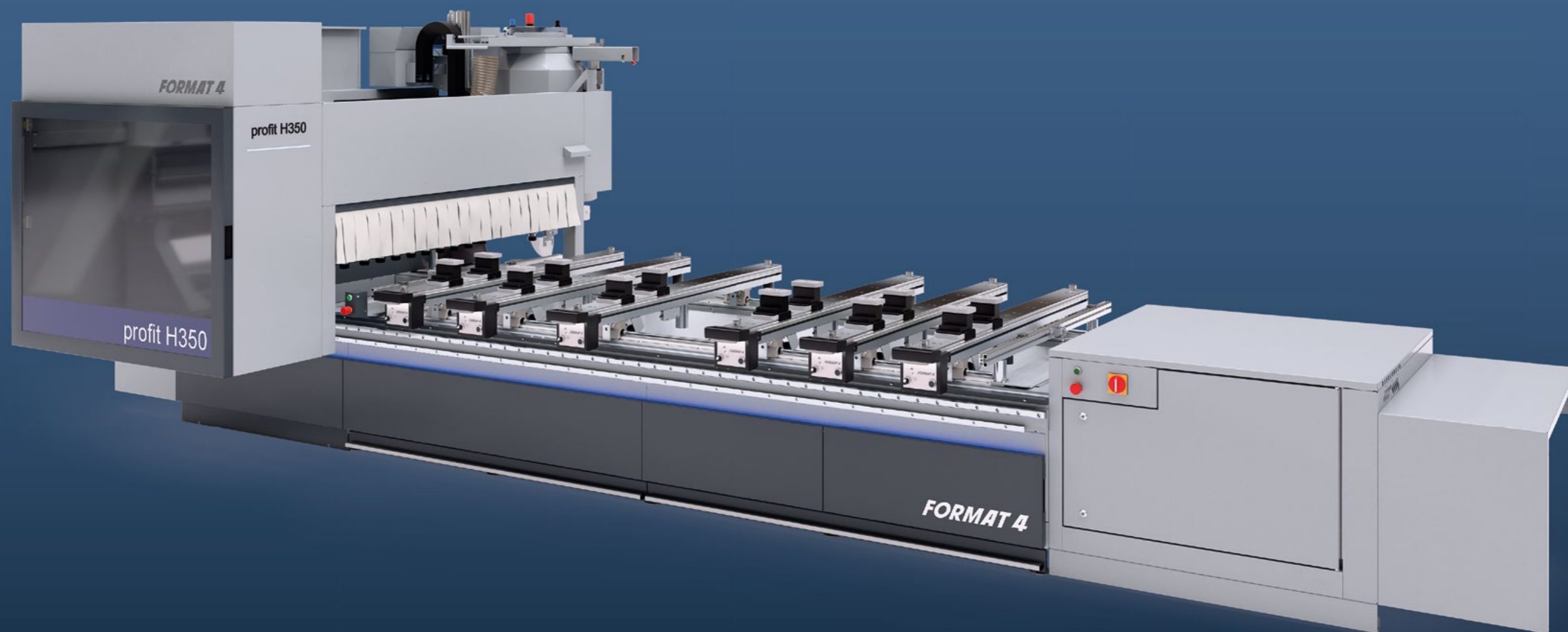

**FORMAT 4**®



# Five axes for universal craftsmanship

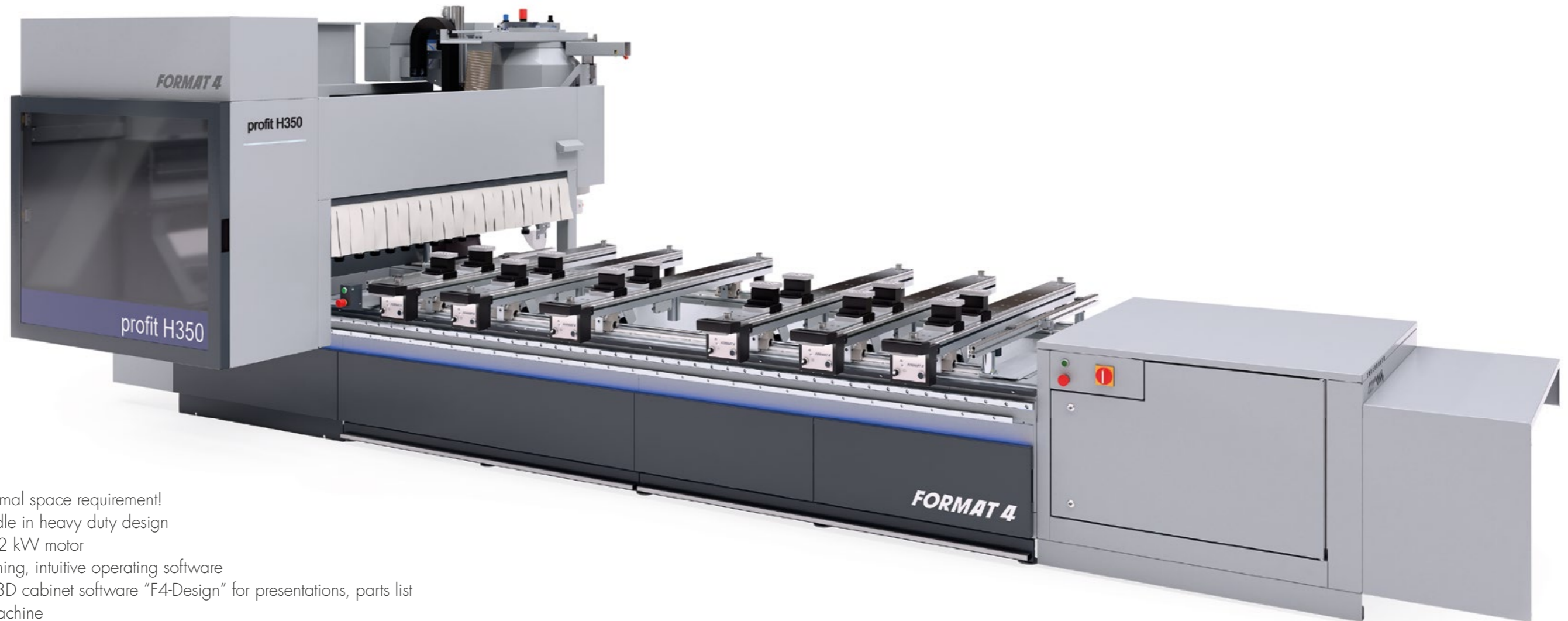

## profit H350R

- » Small footprint – minimal space requirement!
- » 5 axes moulder spindle in heavy duty design with liquid cooling 12 kW motor
- » Drawing = programming, intuitive operating software
- » CNC software incl. 3D cabinet software "F4-Design" for presentations, parts list and connection to machine
- » Gantry design, synchronized drive, solid construction for maximum performance
- » The drilling head covers the whole working field
- » High quality dual circuit vacuum clamping system with 100 mm vacuum pod height
- » Large Y dimensions for maximum processing depth
- » **F4<sup>®</sup>Solutions**<sup>ready</sup>

It is universal workshops in particular, where the individual processing of various materials is becoming increasingly important. The most up-to-date 5 axes CNC technology guarantees limitless creativity, and at the same time reduces the initial investment cost and subsequent costs for special aggregates and tools.

## FORMAT4 Premium Machines for Premium Requirements

- |   |   |
|---|---|
| <ul style="list-style-type: none"> <li>» Constantly high performance in industrial continuous operation</li> <li>» Customer specific optimized production solutions</li> <li>» Solid design with premium components</li> <li>» Wide range of configuration packages with high-tech solutions</li> <li>» Complete engineering precision</li> <li>» Premium user comfort</li> </ul> | <ul style="list-style-type: none"> <li>» Quality and precision from AUSTRIA</li> <li>» Uncompromising productivity</li> <li>» Perfect service package before, during and after the purchase</li> <li>» Tailor made financing solutions</li> <li>» Mechanical engineering experience since 1956</li> </ul> |
|---|---|

# The most important highlights at a glance



### lightPos – LED vacuum pods positioning, revolutionarily simple & precise

With lightPos, workpiece positioning during alternating operation is carried out without expensive set-up times. Top of the range comfort! Thanks to a sophisticated color management system, each vacuum type and its orientation is displayed in well-defined colors. RGB LEDs on the X-axis give information about the processing status. LEDs along the X- and Y-axis visualise the position and the dimension of the workpiece.

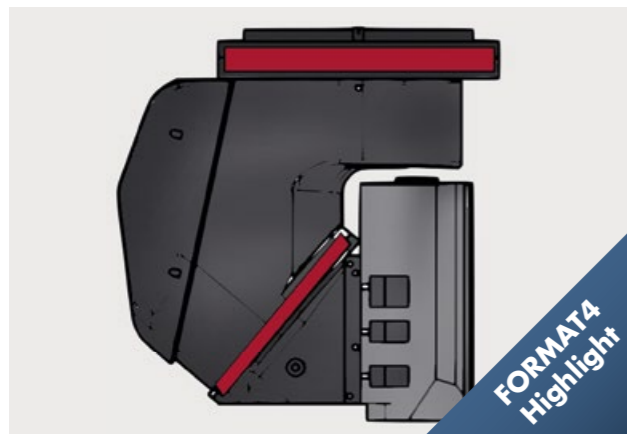

### Mechanical Axis Lock System

The mechanical locking of the C and A axes increases the service life of the spindle and at the same time improves the surface finish of the finished component.



### autoPos automatic console and vacuum pod positioning

autoPos automatic console and vacuum cup positioning for quick and precise positioning of the console in the X direction and vacuum cups or frame clamps on the console in the Y direction. For positioning in the X direction, each console is equipped with an independently controlled motor, which reliably and accurately moves the consoles to the respective position defined in F4 Operate. For positioning in the Y direction, the clamping devices are lifted on both sides by means of lifting bars. The integrated blow-off device on the belt-driven driver ensures that the console is always properly cleaned, preventing any residual dust from accumulating between the console and the clamping device. Another highlight is the automatic positioning of up to 6 vacuum suction cups per console – or alternatively 2 frame clamps. Depending on the equipment, repositioning during oscillating operation is also possible. Recommended software feature: 'Advanced vacuum pod positioning'

# FORMAT 4®

## Details

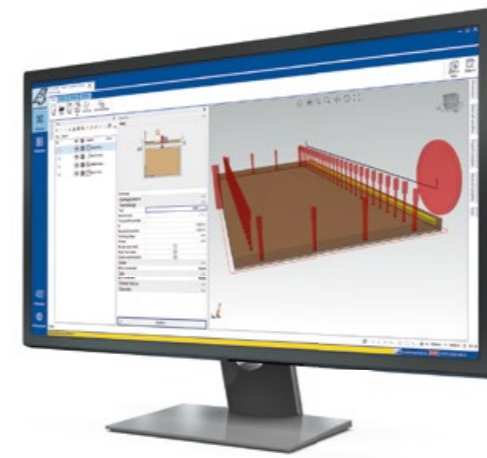

### F4®Integrate: The pioneering CNC software

For the highest demands, all inclusive – tool library, programming section and an operator control panel on the machine with a consistent and intuitive user interface. F4®Integrate is a software developed by Format4®. Developed from practical experience for practical use in cooperation with our CNC customers, F4®Integrate meets the highest demands in modern CNC machining.

Enjoy the comfort of a state-of-the-art and well-coordinated user interface. Tool library (F4Toolbox), programming section (CAM area with integrated CAD area, F4Create) and machine operation control (F4Operate) all packed into just one single screen, with a consistent and intuitive user interface.

F4Integrate is based on G-Code, so external industry programs can be easily connected and the transfer of programs smoothly organized.



### Rows of stops

For this purpose, the H300 series is equipped with rear and center stop rows. An additional front stop row is also available as an option. The solid cylinder stops allow flexible component referencing of small, medium and large workpieces on the work area.



### Maintenance opening.

For quick access to change the drill or maintenance work, the hood can be easily opened on all CNC machining centers.



**The main spindle:  
5 axes – no restrictions**

The high performance 5 axes spindle with 12 or optionally 15 kW motor guarantees excellent results when milling, drilling and cutting at every angle. The special liquid cooling and high quality ceramic bearings ensure durable precision and processing smoothness of every material. An inverter regulates the speed up to 24,000 rpm.

# FORMAT 4®

**Automatic central lubrication system:**

The lubrication is applied as and when required to the guide carriages of the X, Y and Z axis as well as the bearing spindles in Y and Z. Lubrication is carried out automatically after a preset time.

**Linear guides**

**X-axis guiding system:**

Positioning is carried out by recirculating ball bearings running along hardened and polished linear guides. The X-axis is positioned via a cambered rack and pinion gear.

**Y- and Z-axis guiding system:**

Positioning is carried out by recirculating ball bearings running along hardened and polished linear guides. The Y- and Z-axis is positioned by a polished recirculating ball spindle.

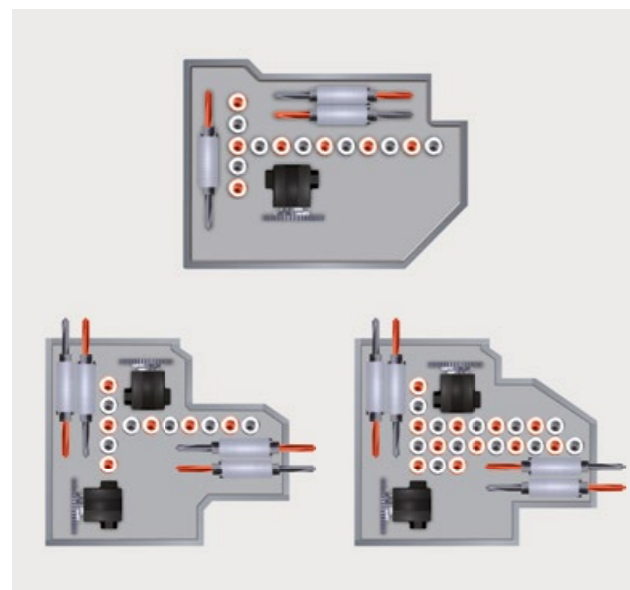
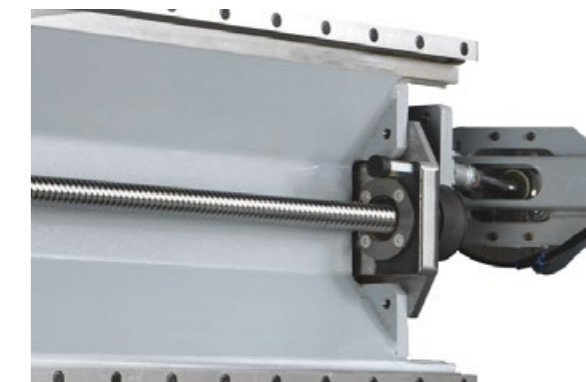

**Individual drill head configuration**

Regardless of whether the machine will only be used for cabinet manufacturing or as an all-rounder, you can decide which drilling head configuration is the right one for you. Choose between, a drilling head with only vertical spindles or one with spindles and a grooving saw for vertical and horizontal processing. Inverter controlled motor up to 7500 rpm

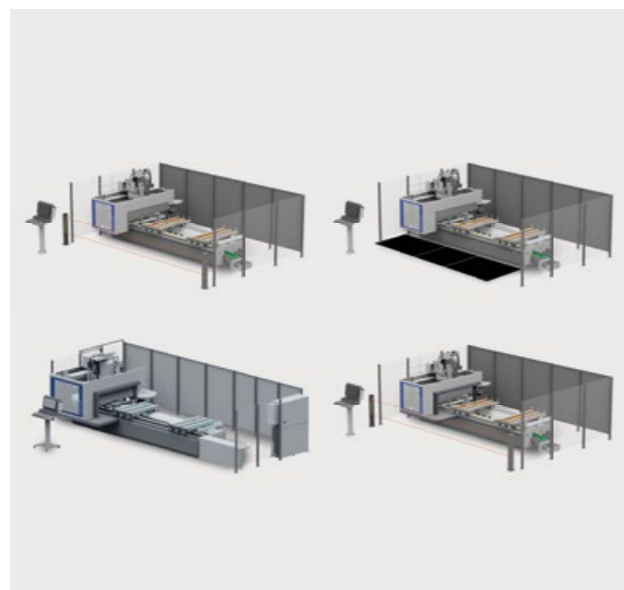

**Safety Concepts can be Freely Selected**

In order to be able to offer our customers different advantages (user-friendliness, productivity, space requirement,...), the machine is available with several safety concepts:

- » Light barrier
- » Foot mat
- » Bumper



**Flexible and unrestricted use of clamping devices**

A variety of vacuum pod shapes guarantee the secure positioning of any kind of workpiece shape. In addition, the number of vacuum suction pads and clamping devices can be used flexibly on the entire console without restriction.



**Positioning display of consoles and vacuum pods**

In the standard configuration, the workpiece, the workpiece supports and the vacuum suction pads are displayed simultaneously on the CNC board. This guarantees, that the workpiece is securely positioned and that there can be no collision between the tool and vacuum pod. The exact position of the vacuum pods on the consoles is shown using a laser. The lightPos system is available as an extension to our standard positioning aid.



**2-Circuit Vacuum Management**

Thanks to the 2-circuit vacuum management on our consoles, the clamping devices are locked before the workpiece is positioned. The vacuum suction pads can therefore no longer be moved and process reliability is considerably increased.

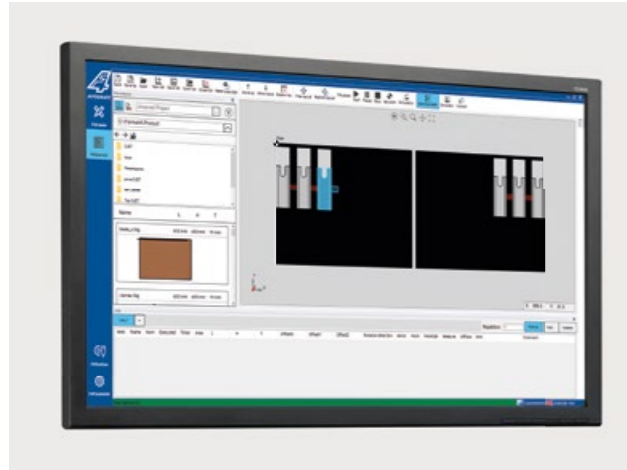

**Intuitive touch-screen control on a 24" monitor**

The advanced and intuitive touch-screen control concept guarantees maximum user friendliness. The clearly structured and self-explanatory user interface allows you to operate the machine with ease and ensures maximum productivity. The machine controls are clearly displayed graphically and various programs, set-points and commands can be executed quickly, easily and accurately at the touch of a button.



**Workpiece stop for veneered panels**

In addition to the workpiece fence cylinders there are also separate fences available for the processing of veneered surfaces with a projecting edge or laminated panels.



**Longitudinal measurement system**

The automatic length measuring unit determines the tool length with an accuracy of one hundredth of a millimeter directly within the machine. This eliminates measuring errors by the machine operator.

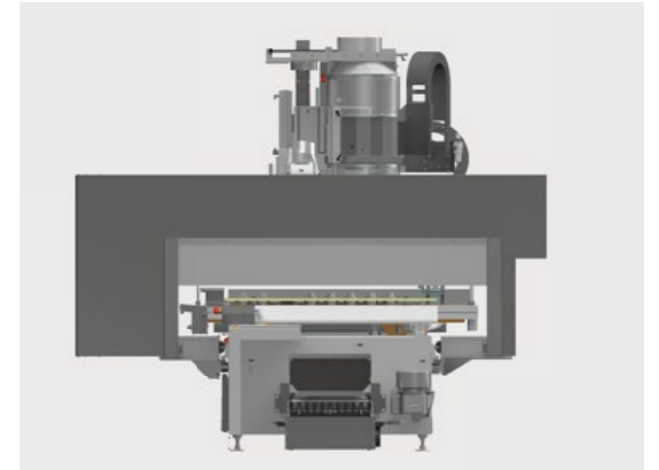

**CNC machining center with gantry design**

The machine chassis is made of thick-walled, electro-welded shaped tubes.

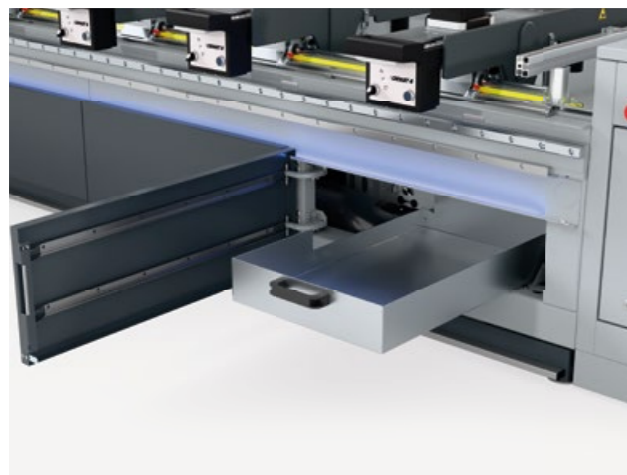

**Chip conveyor**

Chip conveyor for waste pieces and residual chips and dust: For the removal of offcuts and chips from the machine chassis (right hand side). At the end of the conveyor belt they are separated using a separating slide and then extracted. The offcuts are collected in a container.

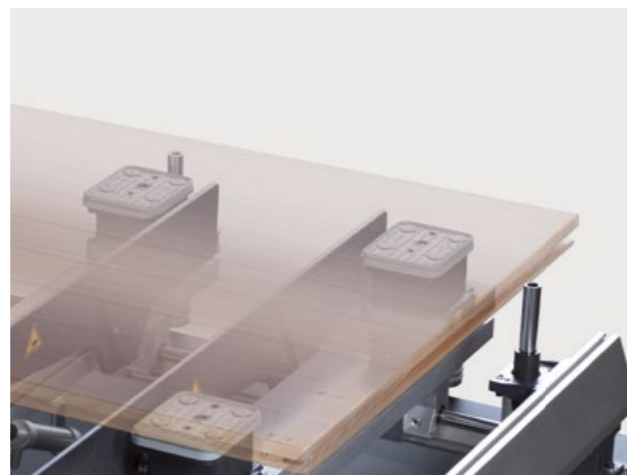

**Workpiece loading supports**

Loading supports assist in the simple loading and unloading of large or heavy workpieces. A major advantage is that they enable you to operate the machining center with one person.

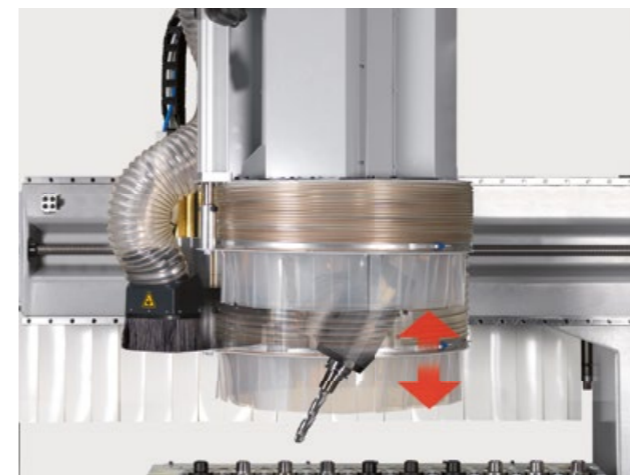

**Variable position controlled extraction hood**

The extraction hood adjusts itself fully automatically to the workpiece height which significantly reduces the dust and noise emissions.



**Console activation**

Specially designed for use with compressed air controlled frame clamp systems, this function offers new possibilities and enormous clamping strength when it comes to the processing of solid wood. The ability to be able to deactivate the consoles individually makes it possible to remove offcuts without having to release the vacuum that is holding the workpiece. This ensures that the workpiece stays in exactly the right position for the next working process (inner profiles etc.).

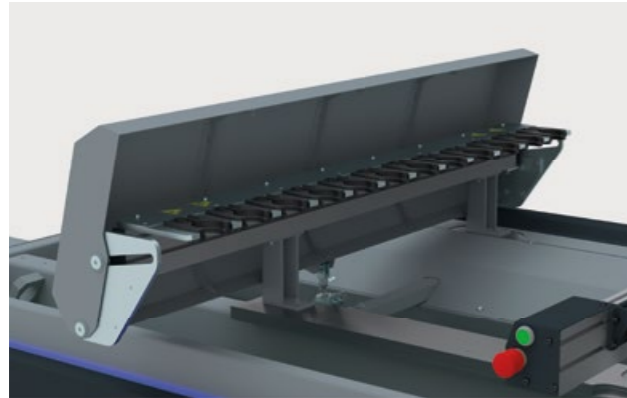

**12 position linear tool changer**

The 12-position linear tool changer on the left side of the machine stand also offers the option of storing up to 3 units. In addition, the frontmost unit storage position can be used as a pick-up station for hard-to-reach tool changing stations.

The cover optimally protects the high-precision HSK tool adaptors from dust and chips.

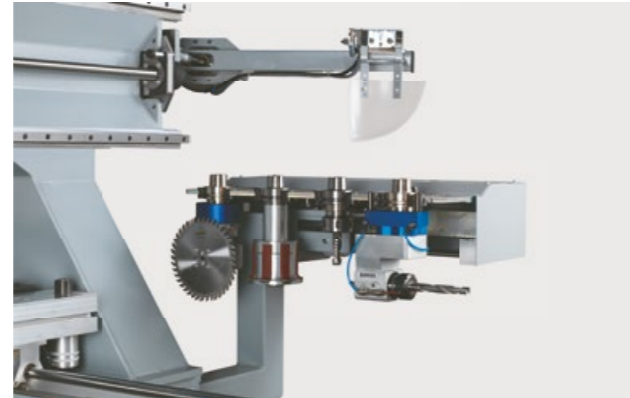

**4 position linear tool changer moving in the X-axis direction**

Tool changer for 4 tools or aggregates, mounted to the gantry. Ensures quick tool changes even when working in pendulum operation.



**Rotary tool changer, mounted to the outrigger**

The rotary tool changer with 18 tool positions is mounted to the back of the outrigger and moves with the outrigger along the X-axis. The 18 position rotating tool changer, keeps tool changing times to the bare minimum. This makes the Format4 machining center even more powerful!

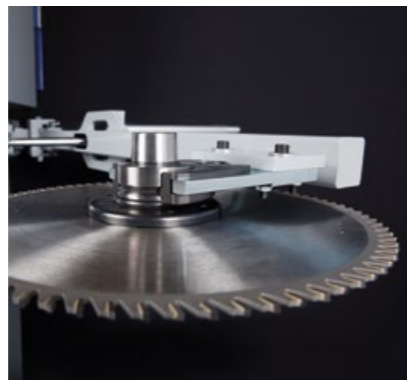

**Saw blade changer**

Travels with the outrigger for saw blades with a max. 13 3/4" (Ø 350 mm)

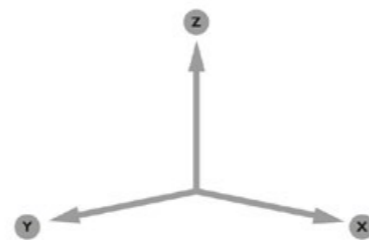

**Two working field size options for individual requirements**

**profit H350 16.30**  
 X= 9 ft 10 7/64 in (3000 mm)  
 Y= 5 ft 2 13/64 in (1580 mm)  
 Z= 9 27/32 in (250 mm)  
 (clearance height starting from bracket height)

**profit H350 16.50**  
 X= 16 ft 4 27/32 in (5000 mm)  
 Y= 5 ft 2 13/64 in (1580 mm)  
 Z= 9 27/32 in (250 mm)  
 (clearance height starting from bracket height)

**3D simulator with collision control**

The 3D simulator accurately displays travel distances, feed speeds, travel heights, and optional equipment such as the 5-motion unit, the chip deflector, all rotary tool changers, or drill heads, and determines precise working times. The collision check tests whether any collisions could happen and guarantees the working safety on the machine. Through the allocation of the tool DXF profile, the contour of your router can be shown on the workpiece. Even when calibrating new tools, the DXF profile can be used which helps to reduce the amount of material use.

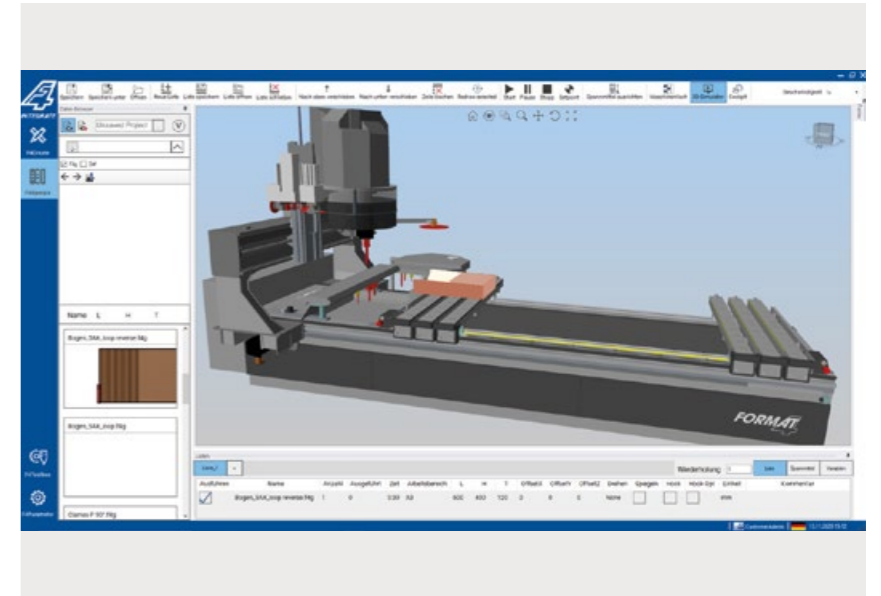

**Status display**

The changing colors of the innovative lighting system display the various machine statuses. This makes it possible to keep up-to-date on the current status of your profit CNC Machining Center.

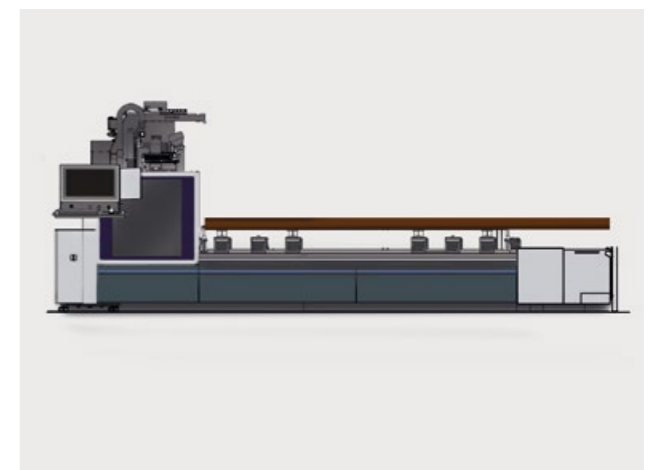

**Flexible Processing of Extra-Long Components**

Tool changer and control cabinet are located below the zero level of the working area. This allows extra-long components to be flexibly clamped and processed in two steps.

**Free Working Area due to Hood Park Positioning**

If the hood is in parking position, the entire working area is freely accessible. The machine operator therefore has no operational restrictions during workpiece positioning.

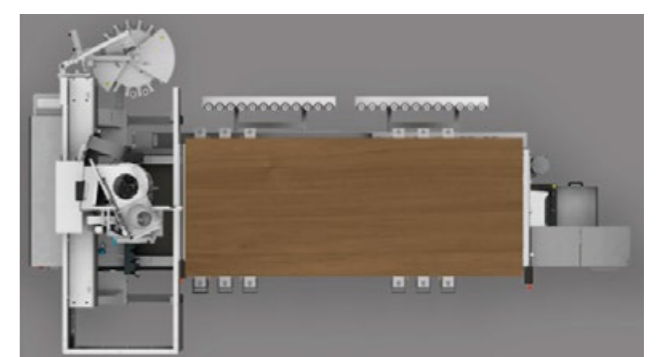



**100 millimeters Suction Pad Height**

Our machines are equipped with vacuum suction pads of 3 15/16" (100 mm) in height. Because of the increased distance between the console and the workpiece, the machining restrictions on the workpiece underside are significantly minimized, as well as when using aggregates on the lateral surfaces.



**Comfort Footswitch Bar**

At the front of the machine, a foot switch bar is integrated in the pedestal along the entire length of the working area. This eliminates the need to search for or move the foot pedal during workpiece positioning. The simple construction blends into the coherent design of the machine.

**LED-vacuum pod indicator integrated into the console handle**

The type and position of the vacuum pods on the workpiece are defined in F4Operate. The LEDs integrated into the console handle allow easy reading of the sequence and type of clamping devices on each console. Different colors indicate the type of vacuum pod and its orientation (0 or 180).

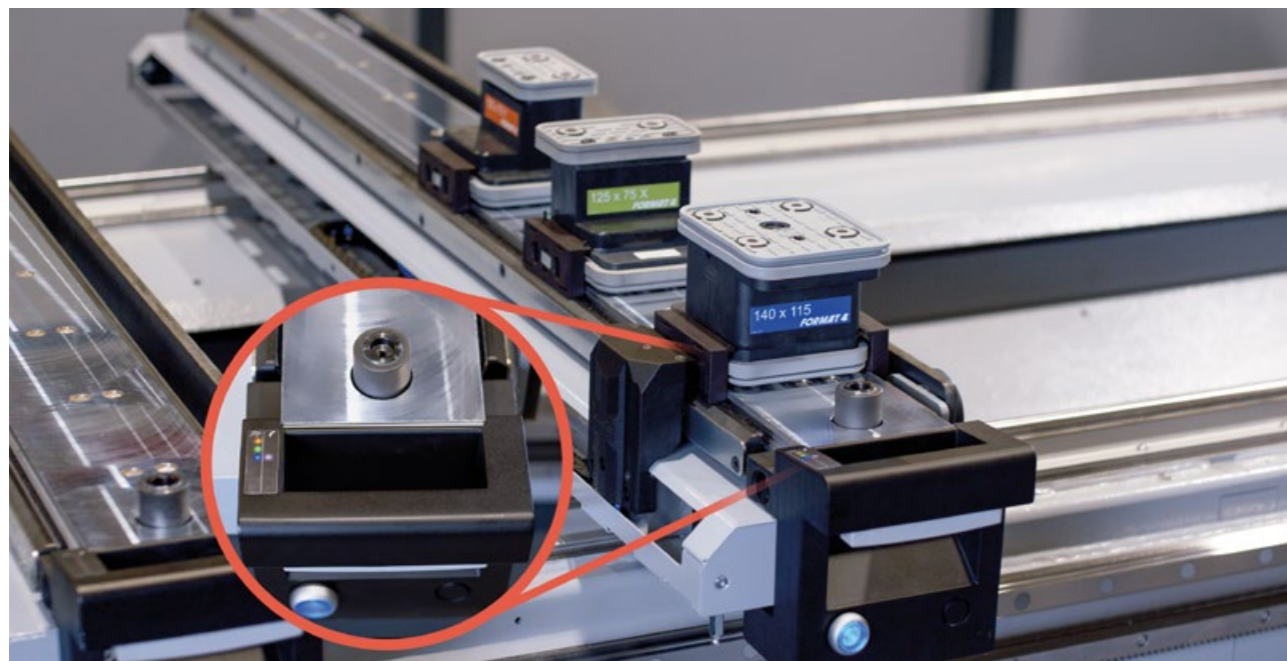

**Product range**



Sliding Table Panel Saws



Shaper Spindles

Planers



Edgebanders



Wide Belt Sanding & Brushing Machines

Heated Veneer Presses



CNC Machining Centers



Nesting-CNC Machining Centers



Beamsaw Vertical saw



Vacuum panel lifter, Return systems & Feeding Units

# ***FORMAT 4***®

## **FORMAT4 Uncompromising expertise for the highest of requirements**

The Felder Group premium brand has met the highest standards of professional users since 2001. The customized high-performance solutions are uncompromisingly innovative, offer maximum operating comfort and complete productivity.

### **FELDER GROUP**

KR-Felder-Straße 1  
A-6060 HALL in Tirol

☎ Tel. 05223 55306

[www.format-4.us](http://www.format-4.us)

[Contact](#)