

**FORMAT 4**®

**profit H08**

CNC NESTING – EFFICIENCY  
THROUGH AUTOMATION



**FORMAT 4**®

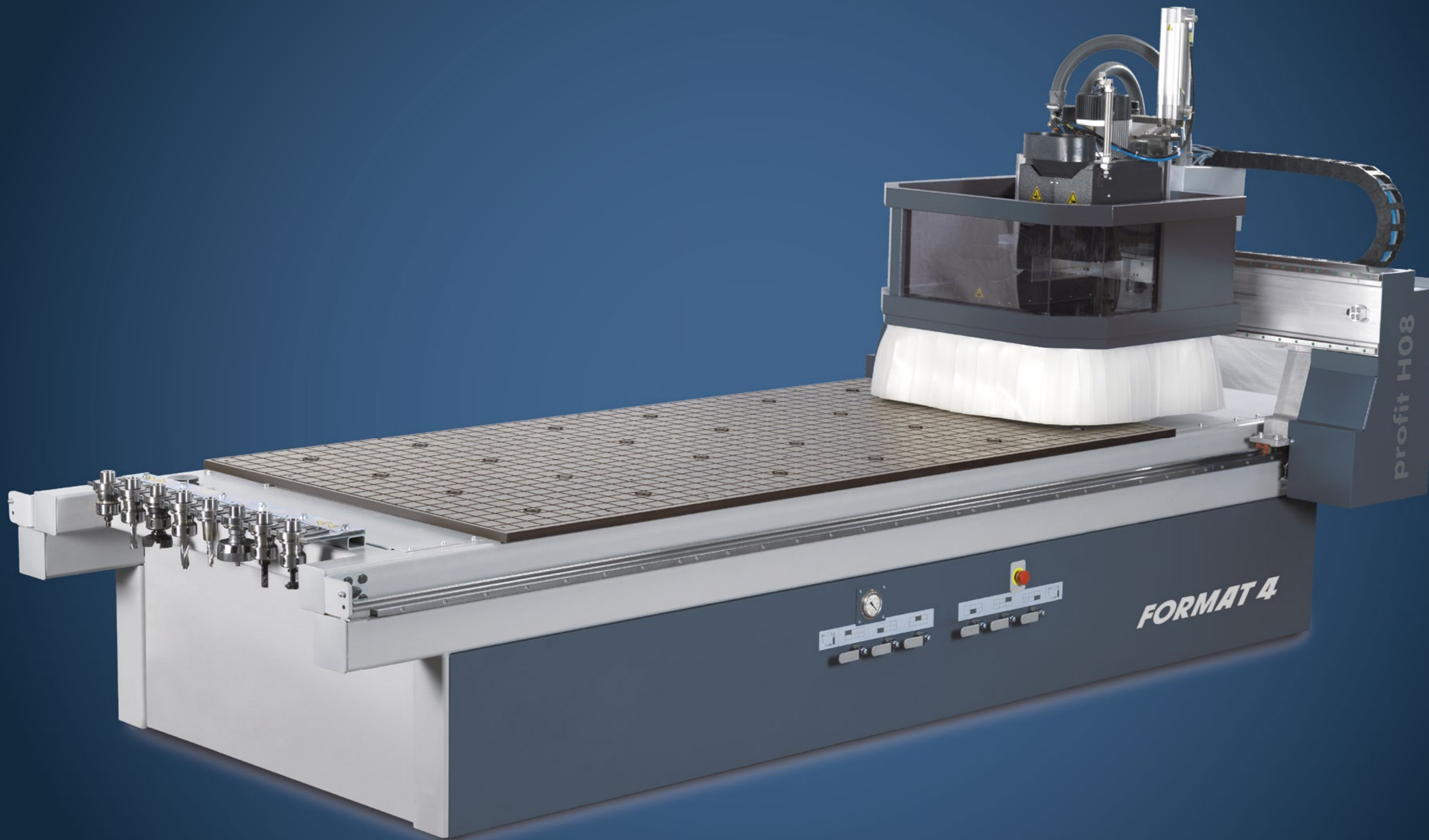

## CNC Nesting – efficiency through automation



Specially developed for universal application, the profitable Format4 CNC all-rounder impresses with the highest precision and outstanding productivity when processing a wide range of materials.

The profit H08 from Format-4 is the CNC-machining center for professional nesting applications, and requires only minimal space. Offering maximum flexibility and efficiency, even in its basic version with 1.5 tool slots, it is a convincing choice. For perfect, chip free results, the main spindle is equipped with a 12 kW motor. The main spindle is completed by a drilling head with 8 spindles.

Due to the smart zoning vacuum control, the vacuum zones can be switched to either fully automatic or manual control and activated depending on the workpiece size. Individual workpieces with variable sizes can also be positioned and processed in the zones 1 to 6.

Plexiglas up to a thickness of 1 ½" (40 mm) can be machined tension-free, precise and efficient with the powerful CNC machine center optimized for plastics processing, and the profit H08 is also unbeatable with printed materials such as displays.



### profit H08

- » Small footprint - minimal space requirement!
- » Drawing = programming, intuitive operating software
- » "Woodflash" software
- » Gantry design, synchronized drive, solid construction for maximum performance
- » Automatic tool length measuring system
- » Perfect nesting with the matrix table made from phenolic resin
- » F4 Capture – fiducial marker recognition
- » **F4<sup>®</sup>Solutions<sup>ready</sup>**

### profit H08 21.31

- » Automation with unloading unit
- » Smart zoning – flexibly assignable vacuum fields
- » Aggregate interface with fixed position
- » Small footprint - minimal space requirement!
- » Drawing = programming, easy to use software
- » "Woodflash" software
- » Gantry design, synchronized drive, solid construction for maximum performance
- » Automatic tool length measuring system
- » Perfect nesting with the matrix table made from phenolic resin
- » **F4<sup>®</sup>Solutions<sup>ready</sup>**

### profit H08 c-tech

- » Small footprint - minimal space requirement!
- » Drawing = programming, intuitive operating software
- » "Woodflash" software
- » Gantry design, synchronized drive, solid construction for maximum performance
- » Automatic tool length measuring system
- » Perfect nesting with the matrix table made from phenolic resin
- » F4 Capture – fiducial marker recognition
- » Adjustable, controlled compressed air and cold air jets

### profit H08 21.31 c-tech

- » Smart zoning – flexibly assignable vacuum fields
- » Stress-free acrylic glass processing up to a thickness of 1 ½" (40 mm)
- » Aggregate interface with fixed position
- » Small footprint - minimal space requirement!
- » Drawing = programming, easy to use software
- » "Woodflash" software
- » Gantry design, synchronized drive, solid construction for maximum performance
- » Automatic tool length measuring system
- » Perfect nesting with the matrix table made from phenolic resin
- » F4 Capture – fiducial marker recognition
- » Adjustable, controlled compressed air and cold air jets

## FORMAT4 Premium Machines for Premium Requirements

- » Customer specific optimized production solutions
- » Solid design with premium components
- » Wide range of configuration packages with high-tech solutions
- » Complete engineering precision
- » Premium user comfort
- » Award winning design
- » Quality and precision from AUSTRIA
- » Uncompromising productivity
- » Perfect service package before, during and after the purchase
- » Automation solutions
- » Networked workshop
- » Machines and software from one supplier
- » Tailor made financing solutions

# The most important highlights at a glance

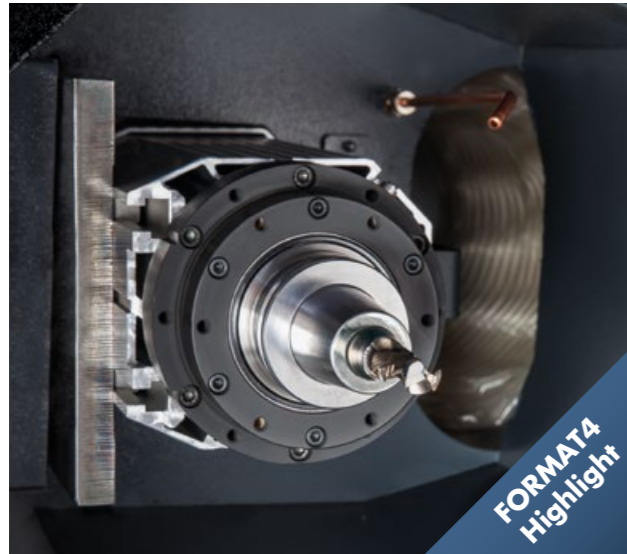

### Spindle

With a motor power of 10 and 12 kW (depending on the series) and up to 24,000 rpm, the milling motor is controlled using an inverter and is attached directly to the support module of the drilling head in the Z axis. Dual linear guides guarantee highly precise vertical guiding. The main motor is positioned using ground ball screws. The HSK F63 tool clamping is done automatically. The clamping of the tool is checked using sensors, which then confirm that it is safe to start the operation. The tool holder is cleaned automatically.

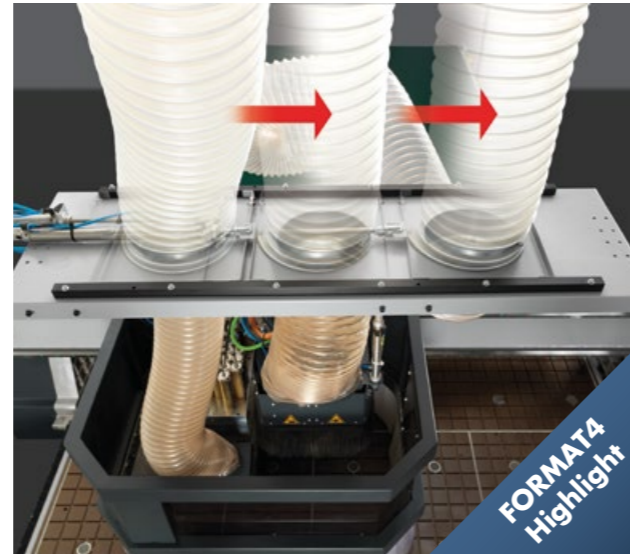

### Activation controlled extraction connections

With the automatic control of the extraction connection, the full extraction capacity is moved between the drilling head and main spindle, depending on what is being used at the time. Efficient extraction results guaranteed. With the pushing unit option, a third position of the extraction connection is controlled. This extracts the dust from the table ensuring an optimized work process.

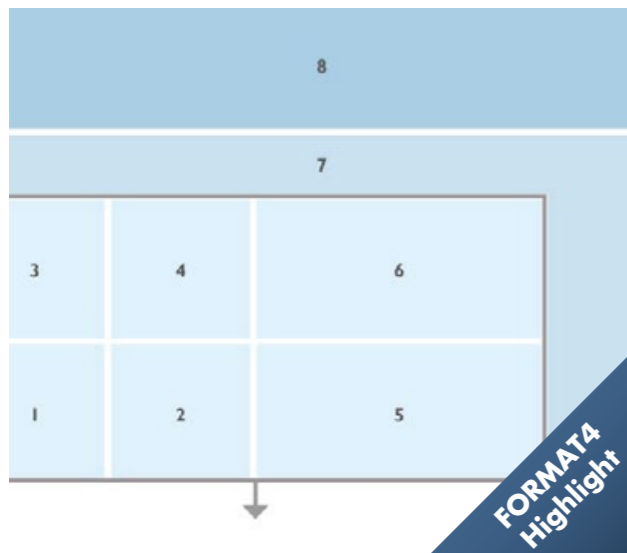

### Smart Zoning

Smart Zoning offers the quick processing of several panel formats of 121 5/8" x 82 11/16", 121 5/8 x 60 1/4", 98 7/16" x 49 7/32". It is possible to quickly change from one panel format to another.

# FORMAT 4®

## Details



### Vacuum system

Air-permeable materials and small parts are held in place with a maximum holding force – up to 750 m³/h.



### Automatic measuring system of the tool length

Parameterizing your tools made easy: Each tool length in the database is provided with an accuracy of a hundredth of a millimeter.

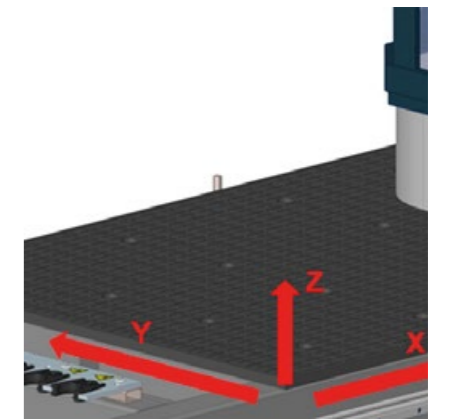

### Three working area sizes for individual requirements

**FORMAT4 profit H08 13.25**  
X= 98 7/16", Y= 49 7/32"  
Z= 3 11/32"

**FORMAT4 profit H08 16.31**  
X= 121 5/8", Y= 60 1/4"  
Z= 3 11/32"

**FORMAT4 profit H08 21.31**  
X= 121 5/8", Y= 82 11/16"  
Z= 3 11/32"

### Complete customized maintenance packages

The continuous availability of modern woodworking machines is a significant influencing factor on the productivity and profitability of a company. Continuous, preventive maintenance procedures ensure the operational readiness of your machine and guarantee constant precision. With our individual maintenance packages, you benefit from long-term consistent high quality of the finished products. In addition to a comprehensive machine maintenance, all electrical, pneumatic, and mechanical components as well as all safety devices are checked. Furthermore, you will also benefit from our complimentary hotline service and receive special terms on software, training, and replacement parts. Find out more about your individual maintenance package now and enjoy perfect woodworking results for years to come!

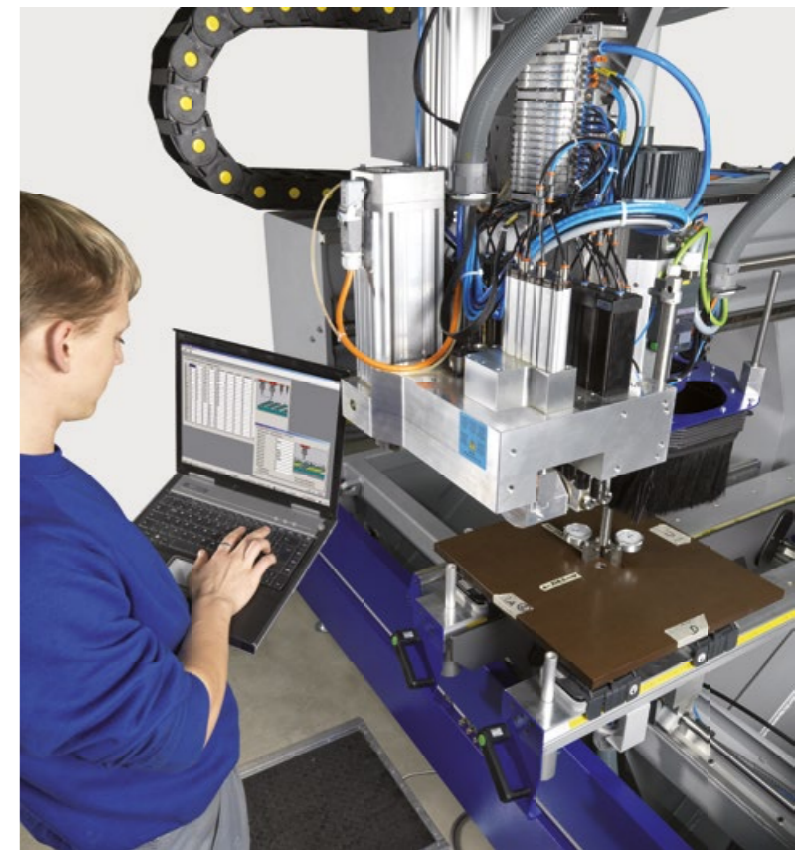



**Engraving**  
 Future applications are not limited solely to wood. Special features also allow the machining of Alucobond.



**Additional seals for extreme operating conditions**  
 High-dust materials can significantly increase the amount of maintenance required on your CNC machining center. Extra seals on guiding carriage and linear guides closed off by brass caps guarantee a noticeably higher operating life, even with heavy use.

# FORMAT 4®

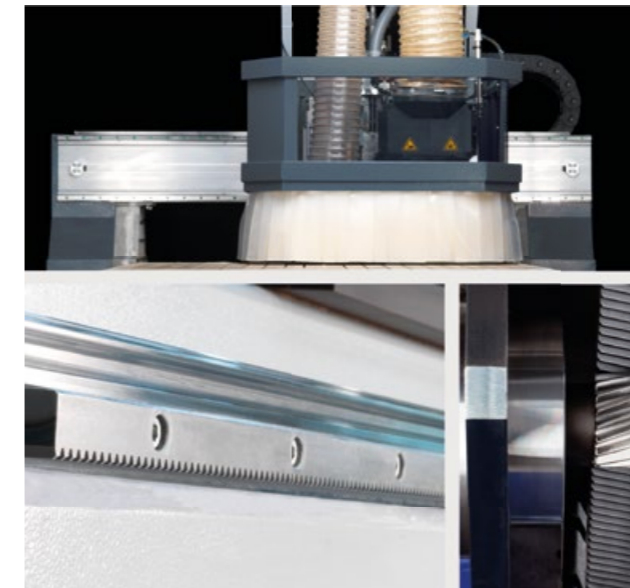

**Portal construction with gantry drive: quick, precise and low maintenance**  
 The dual side driven gantry guarantees maximum precision and repeatability of your processes. The rack and pinion drive in the X and Y direction ensures for maximum traverse speeds for the shortest processing times and tool changing times.



**Drilling head (except c-techprofit H08)**  
 » DH 8 drilling head, with 8 vertical spindles  
 » DH 12 drilling head, with 12 vertical spindles  
 » DH 16 drilling head with 12 vertical and 4 horizontal spindles and 2 saw blades  
 » Inverter driven motor up to 6,000 rpm

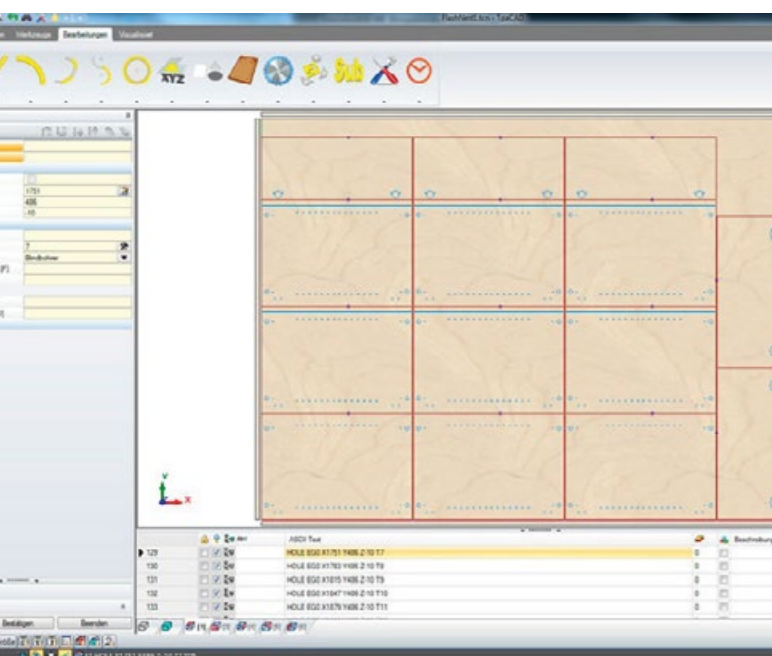

**Format4 Software – Programming has never been easier**  
 With the software that has been especially developed for the machining center, Format4 offers a reliable complete package in a class of its own. For professional CNC machining, two control options are available: “Compact-Control” makes it possible to run ISO-codes and Woodflash programs from external software solutions in conjunction with the Format4 machining center. “Woodflash-Control”, developed by Felder, is the tried and tested software solution for simple and efficient programming. Quick program creation and high automation options, a variety of nesting applications as well as barcode connections for networked workshops guarantee efficient programming and maximum productivity.



**Automation with unloading unit including electromotive offloading pusher (except c-tech profit H08)**  
 With the automatic unloading unit for finished workpieces you can take advantage of shorter processing cycles giving you higher productivity and greater yield.

**Ease of use and operational safety in the Format4 electrical cabinet**

The control unit of the CNC machining center is also the key component of the Format4 occupational safety concept. A light sensor monitors any access into the danger area and the emergency stop switch makes it possible to immediately abort any program still running. In addition to numerous electrical components, the control cabinet contains the central CNC control unit. The easy-to-read LED color monitor keeps you informed about all of the important data relating to the program, workpieces, and machine configuration. A potentiometer and the USB port complete the control cabinet as the heart and brain of the profit H08.

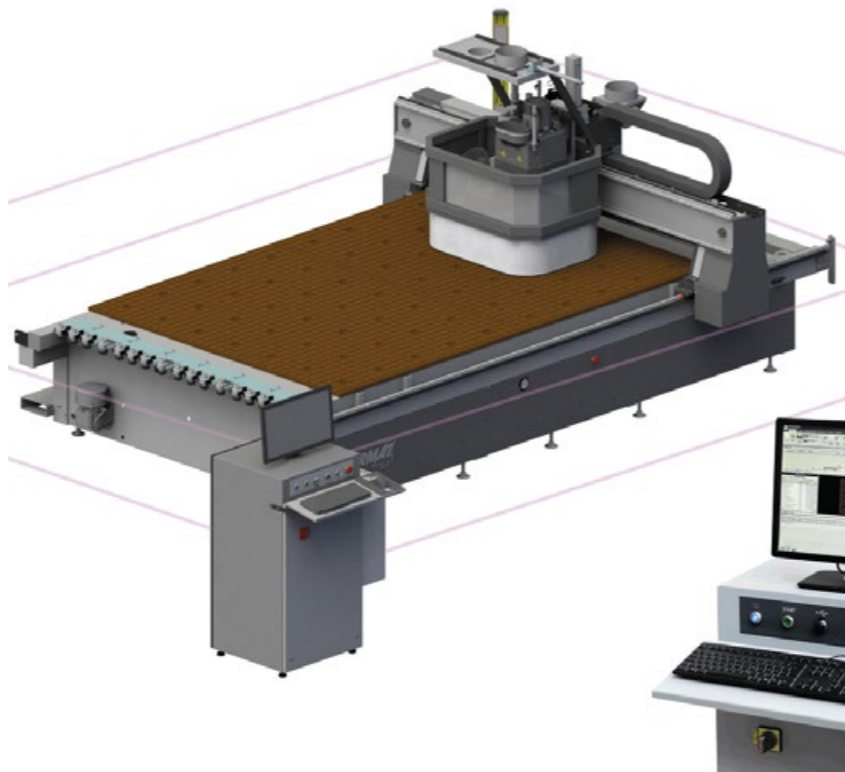

**FORMAT 4®**

**profit H08**

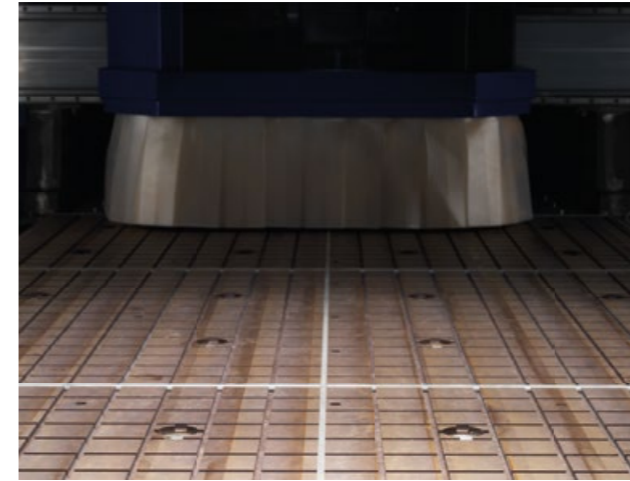

**Vacuum grid table: 60 x 60, 4 vacuum connections per field + phenolic material**

The vacuum table of your profit H08 comes with a grid of 60 by 2 1/4" and 4 vacuum connections per field for even distribution of vacuum and maximum suction performance across the full nesting table. An upgrade to a grid pattern of 30 by 1 3/16" is available for best possible hold down effects for all sorts of shapes and sizes but especially for smaller pieces. The vacuum table is made out of phenolic resin, which has the benefit of being non-corrosive and is not affected by heat or cold (expansion and contraction). Accurate precision is guaranteed.

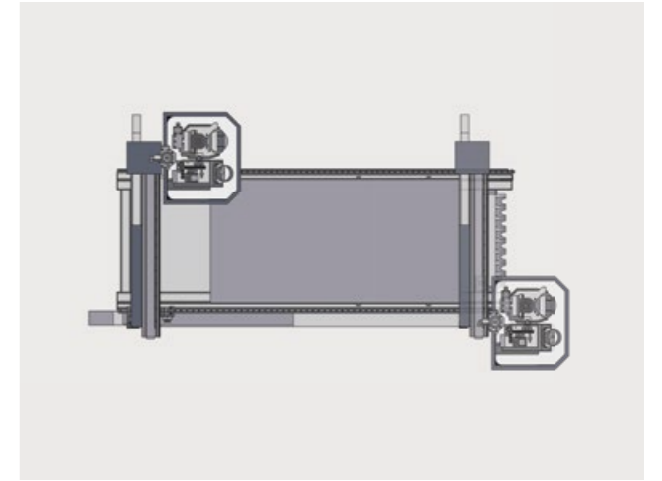

**Working areas, traverse distances**

The working area is subdivided into 6 (H08 13.25) or 8 vacuum fields (H08 16.31) which ensures maximum suction of various different panel sizes. The vacuum field selection is carried out manually using hand levers from the front side of the machine.

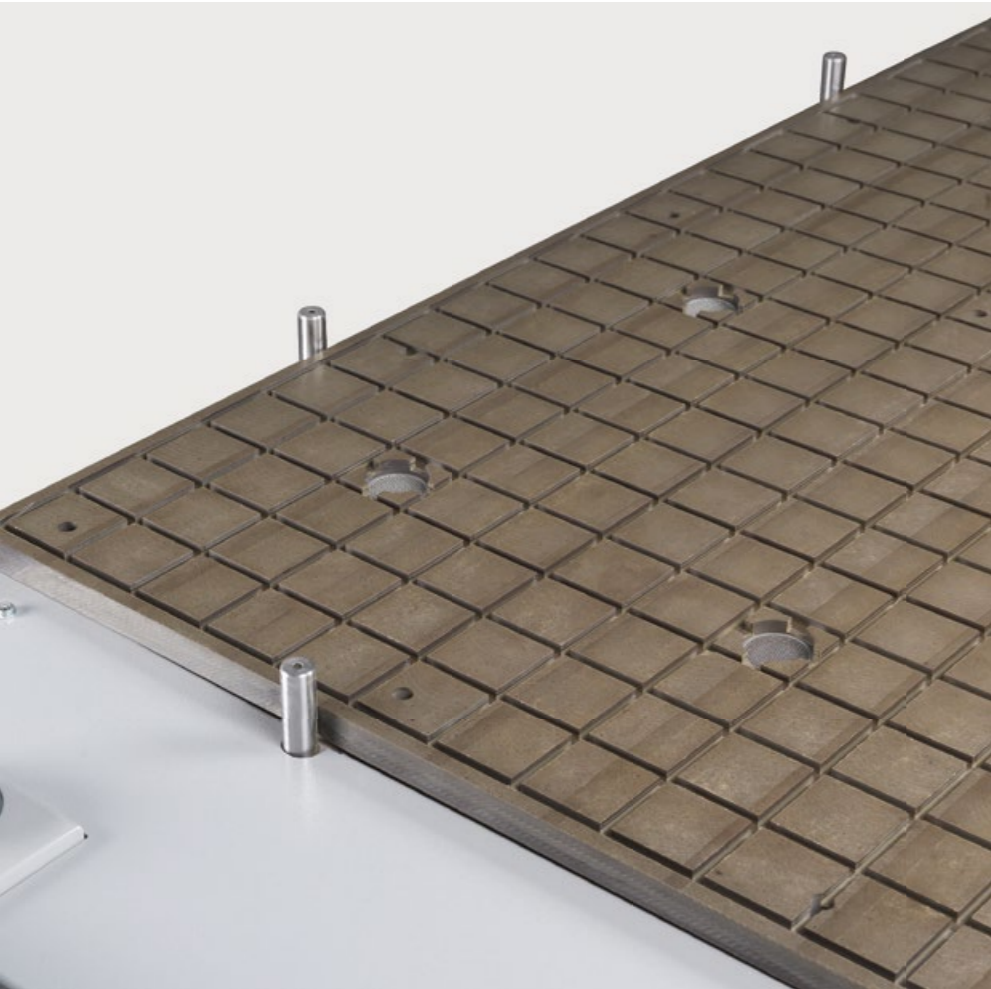

**Perfect nesting with the Format4 matrix table**

The matrix table with optimized grid geometry allows the full surface support of workpieces of all designs and sizes and guarantee their exact positioning. Reference fences mounted directly to the table offer additional support when optimizing off-cuts and can be optionally monitored with collision prevention sensors. Working surface areas of 98 7/16" x 49 7/32" x 3 11/32" on the H08 13:25 and 121 5/8" x 60 15/34" x 3 11/32" on the 16:31, enable simple processing of all standard panel sizes.



**Tool changer**

8, 11 or 15 position tool changer on the side of the machine chassis



**Below table and pusher extraction**

The height-adjustable pushing unit reduces set-up times, as there is no need to adapt the height of the unit to the different material thicknesses.

# profit H08 c-tech



### Adjustable, controlled compressed air and cold air jets (21.31 c-tech)

Compressed air and cold air nozzle with movable hose for tool cooling directly on the moulder spindle and tool cutting edge.

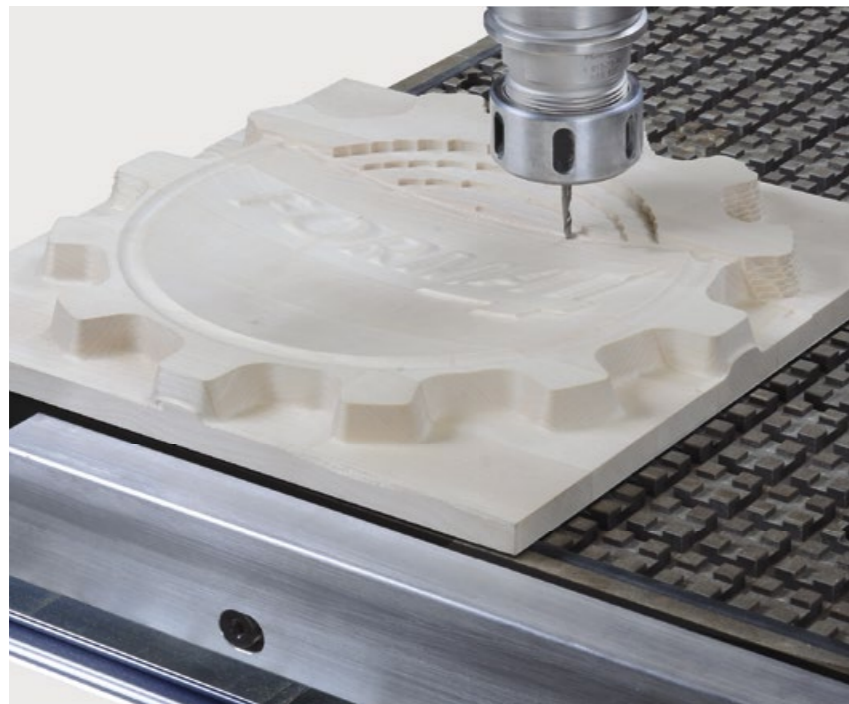

### 3D-Milling

The simplest 3-axis application with incredible results. There is no limit to your creativity.

# profit H08 21.31 & 21.31 c-tech



### Linear tool changer

Generously designed tool change area for automatic operation with convenient storage option for additional units.

### Quick and easy positioning of the vacuum pods, suitable for every workpiece size

The matrix design of the table, makes it easy to handle and position the pods. A distributor can also be used additionally, in order to be able to create a 2 circuit vacuum system.

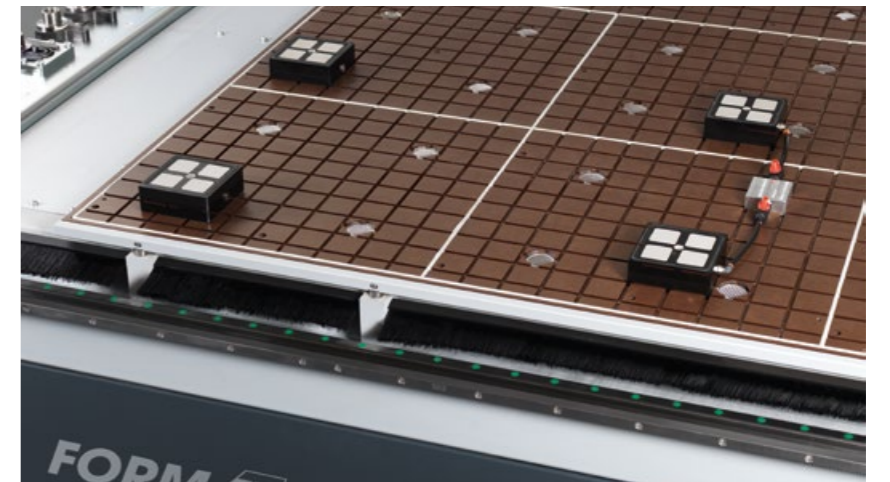

### Aggregate interface with fixed position

On request, the H08 21.31 offers an aggregate mount with fixed positions. This can be rotated 90° manually, so that it can process in all cutting directions.



**Label Printer**

The label printer can be mounted to either the operating terminal of the unloading table or on the standard control terminal.



**Hand-held terminal**

Hand-held terminal with potentiometer and emergency stop.

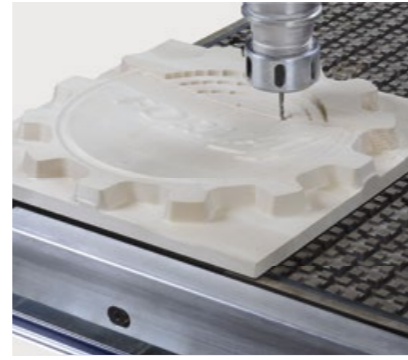

**3D-Milling**

The simplest 3-axis application with incredible results. There is no limit to your creativity.



**Routing screw threads**

Metric thread or fine thread. Simple programming – perfect results.

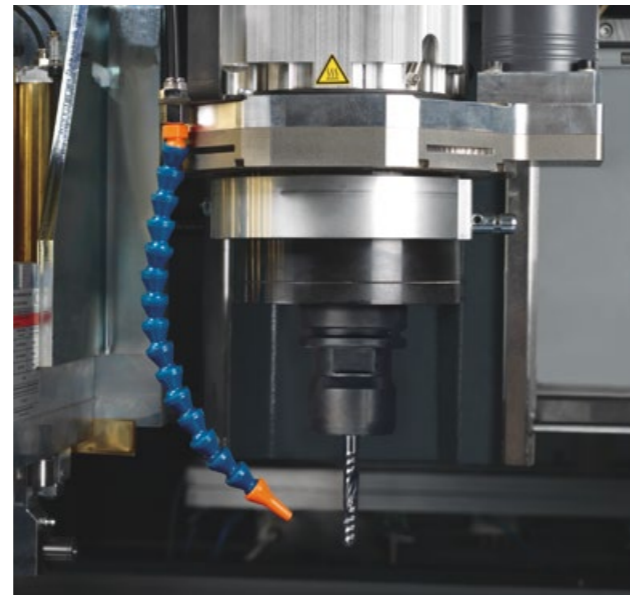

**Adjustable, controlled compressed air and cold air jets (21.31 c-tech)**

Compressed air and cold air nozzle with movable hose for tool cooling directly on the moulder spindle and tool cutting edge.

# FORMAT 4®

## Product range



Sliding Table Panel Saws



Shaper Spindles

Planers



Edgebanders



Wide Belt Sanding & Brushing Machines

Heated Veneer Presses



CNC Machining Centers



Nesting-CNC Machining Centers



Beamsaw Vertical saw



Vacuum panel lifter, Return systems & Feeding Units

# ***FORMAT 4***®

## **FORMAT4 Uncompromising expertise for the highest of requirements**

The Felder Group premium brand has met the highest standards of professional users since 2001. The customized high-performance solutions are uncompromisingly innovative, offer maximum operating comfort and complete productivity.

### **FELDER GROUP**

KR-Felder-Straße 1  
A-6060 HALL in Tirol

☎ Tel. 05223 55306  
[www.format-4.us](http://www.format-4.us)  
[Contact](#)