

FORMAT 4®

profit H100

THE PANEL CUTTING, DRILLING
AND MILLING CENTER FOR
FUTURE-PROOF CARPENTRY AND
JOINERY WORKSHOPS.



FORMAT 4®

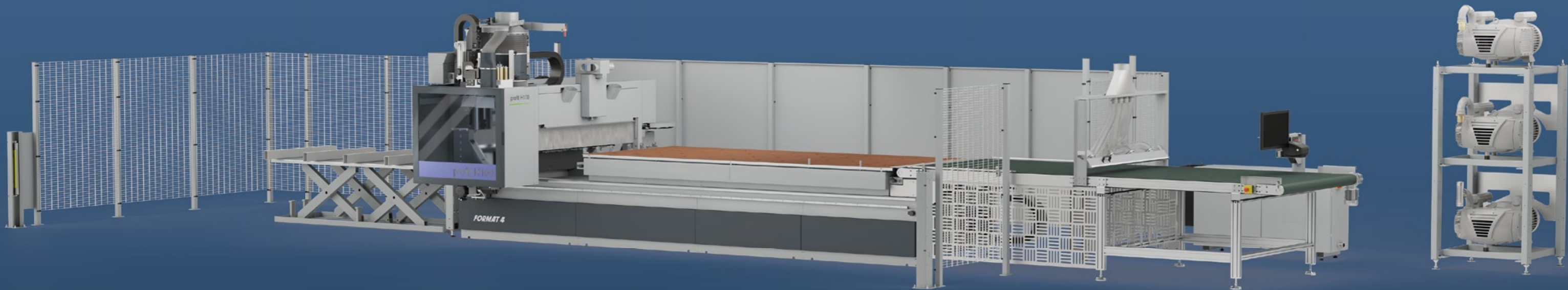

High-end CNC technology at a low investment level

profit H100

- » Intelligent SMART ZONING vacuum management system with pendulum operation
- » Four sizes for every workshop: 16.38, 22.32, 22.43 and 22.61
- » Recessed fence row for unrestricted machining of individual workpieces with a 3- or 4-axis spindle
- » Large Z passage size of 200 mm offers flexible machining of high workpieces
- » Loading and unloading units and with automatic labelling on the loading table
- » Up to 35 tool positions
- » F4[®]Solutions^{ready}



The panel cutting, drilling and milling center for future-proof carpentry and joinery workshops. Entire custom-made furniture with all holes, grooves and connections are produced in one single operation. The latest nesting technologies ensure the highest possible material and time savings. Thanks to various loading and unloading solutions, the Format4 profit H100 can be upgraded to full automation, thus achieving maximum productivity.

Available in four sizes (16.38, 22.32, 22.43 & 22.61) with integrated SMART ZONING vacuum management, high-end automation levels, above-average drill heads, new safety concepts, and much more. For the unrestricted use of the spindle, a recessed series of fence rows is available. A large Z passage size of 200 mm offers flexible machining of high workpieces.

With the standard tool changer and optionally available moving rotary tool changer as well as the pick-up space for a large saw blade, a total number of up to 35 tool places are available. The automatic pre-labelling on the loading table minimizes sources of error and at the same time reduces the processing times.

With the performance package, the CNC control makes the highest industry standard possible. Different optimization levels ensure shorter process times, different milling results and increased comfort in CNC machining.

FORMAT4 Premium Machines for Premium Requirements

- » Constantly high performance in industrial continuous operation
- » Customer specific optimized production solutions
- » Solid design with premium components
- » Wide range of configuration packages with high-tech solutions
- » Complete engineering precision
- » Premium user comfort
- » Award winning design
- » Quality and precision from AUSTRIA
- » Uncompromising productivity
- » Perfect service package before, during and after the purchase
- » Automation solutions
- » Machines and software from one supplier
- » Tailor made financing solutions

The most important highlights at a glance

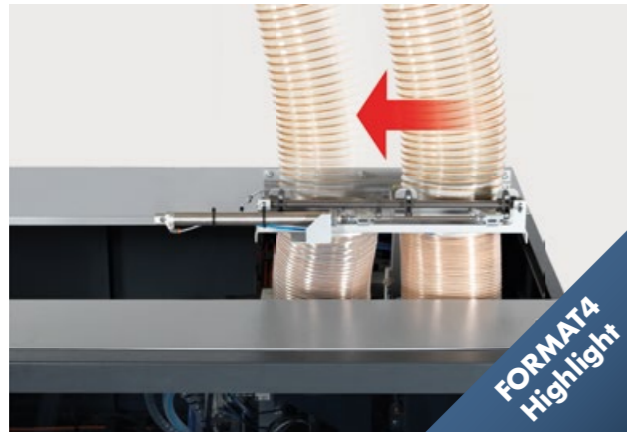

FORMAT4 Highlight

Position controlled extraction connection

With the automatic control of the extraction connection, the full extraction capacity is moved between the drilling head and main spindle, depending on what is being used at the time. Efficient extraction results guaranteed.



FORMAT4 Highlight

Automation solutions

The CNC machining center can be extended to full automation with different loading and unloading solutions, thus achieving maximum productivity.



FORMAT4 Highlight

Smart Zoning

Smart Zoning enables fast processing of several common panel sizes. The fast transition from one panel size to another increases productivity.

FORMAT4®

Details

Spindle

With a motor power of 10, 12 or 15 kW (depending on the series) and up to 24,000 rpm, the milling motor is controlled using an inverter and is attached directly to the support module of the drilling head in the Z axis. Dual linear guides guarantee highly precise vertical guiding. The main motor is positioned using ground ball screws. The HSK F63 tool clamping is done automatically. The clamping of the tool is checked using sensors, which then confirm that it is safe to start the operation. The tool holder is cleaned automatically. The C-axis is available as the fourth axis and is interpolating (360°) with a compressed air interface for aggregates as standard.

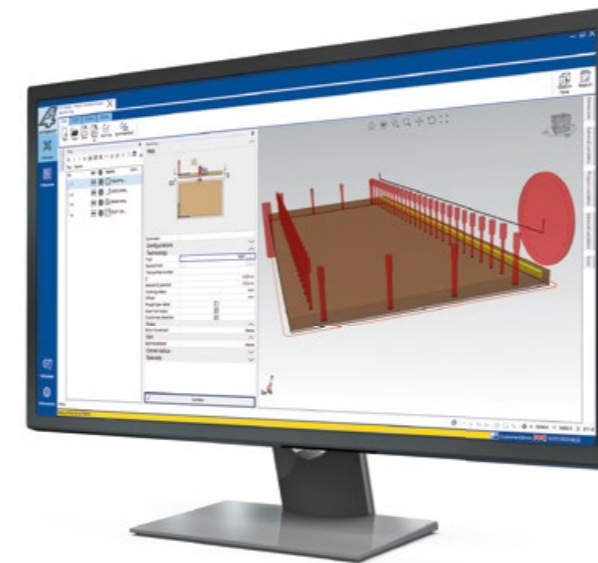

F4®Integrate: The pioneering CNC software

For the highest demands, all inclusive - tool library, programming section and an operator control panel on the machine with a consistent and intuitive user interface. F4®Integrate is a software developed by Format4®. Developed from practical experience for practical use in cooperation with our CNC customers, F4®Integrate meets the highest demands in modern CNC machining.

Enjoy the comfort of a state-of-the-art and well-coordinated user interface. Tool library (F4Toolbox), programming section (CAM area with integrated CAD area, F4Create) and machine operation control (F4Operate) all packed into just one single screen, with a consistent and intuitive user interface.

F4Integrate is based on G-Code, so external industry programs can be easily connected and the transfer of programs smoothly organized.

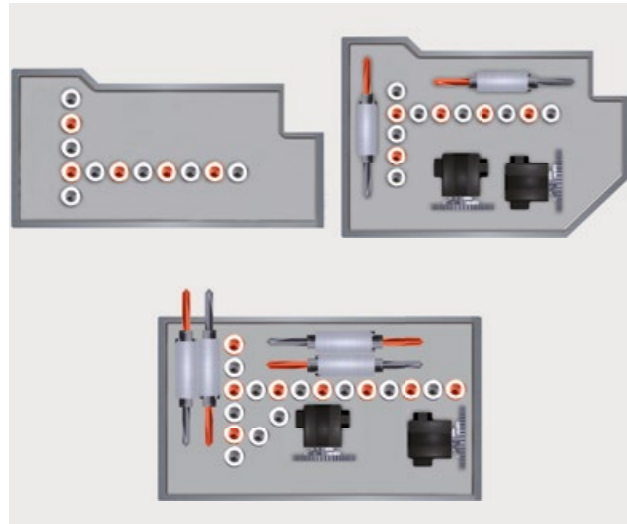

Individual drill head configuration

Regardless of whether the machine will only be used for cabinet manufacturing or as an all-rounder, you can decide which drilling head configuration is the right one for you. Choose between, a drilling head with only vertical spindles or one with spindles and a grooving saw for vertical and horizontal processing. Inverter driven motor up to 7,500 rpm



The C-axis

The C-axis is optionally available as the fourth axis and is interpolating (360°) with a compressed air interface for the units.

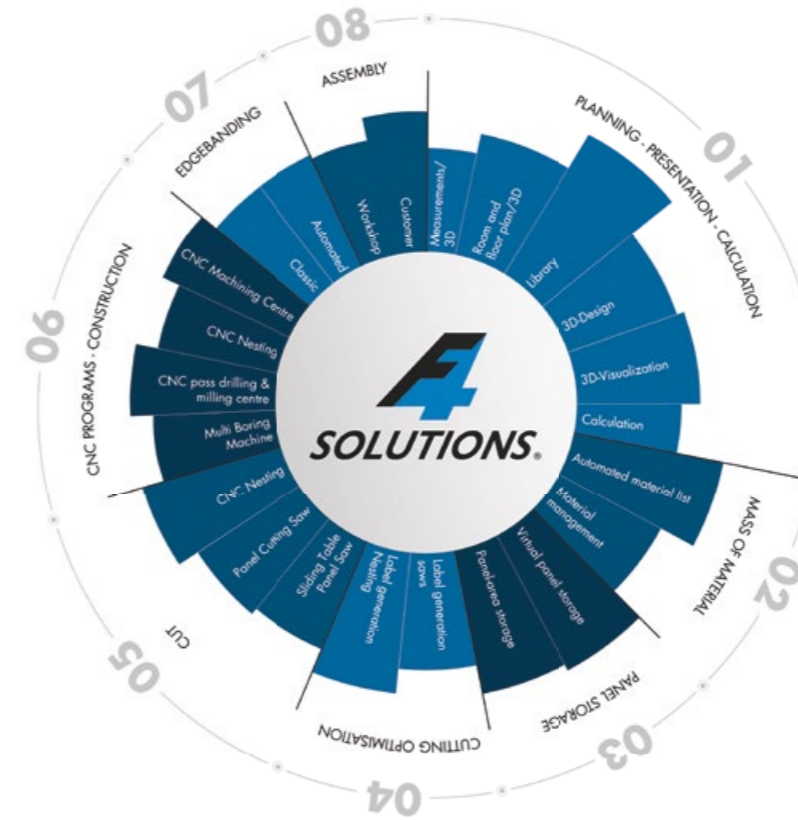

F4®Solutions, the integrated software solution for the cabinetmaker

F4®Solutions generates a consistent, efficient and profitable production process around the piece of furniture. The software tools for maximum productivity accompany you through the entire production chain. Easiest design of individual pieces of furniture in the familiar CAD environment. Photorealistic rendering of sales assisting 3D visualizations. Detailed data transfer to all integrated machines with economic nesting optimization. Even the final assembly is accompanied by clear, detailed drawings and 3D data - that's 4.0 for trade and industry. Watch our videos to learn all you need to know about Craft 4.0 and Industry 4.0.

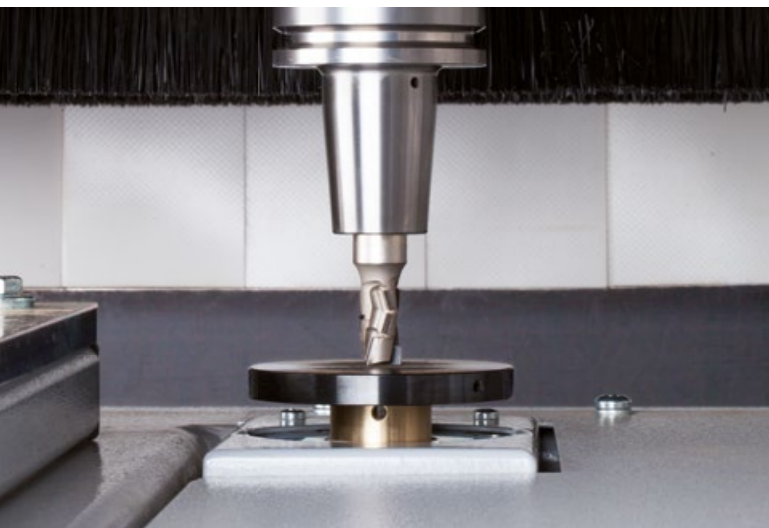

Automatic measuring system of the tool length

Parametrising your tools made easy: Each tool length in the database is provided with an accuracy of a hundredth of a millimeter.

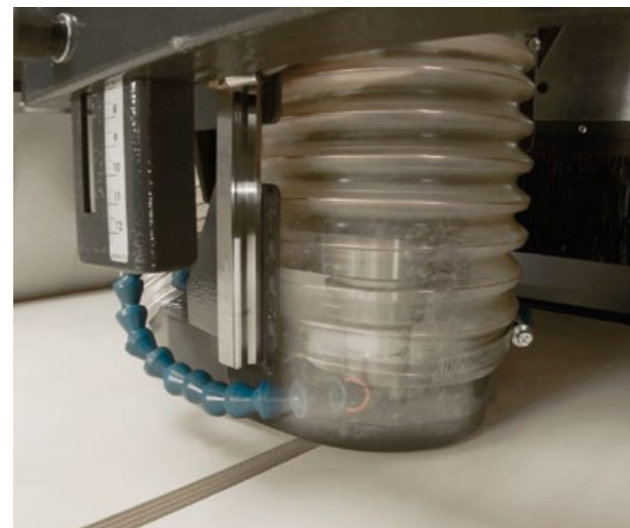

Extraction bell

The extraction bell optimizes the suction results and reduces the required extraction volume due to its compact design.



Vacuum pods

The phenolic resin table also enables the use of vacuum block pods. This gives the machine a whole new character and increases the variability considerably.



5-color status display

The changing colors of the innovative lighting system display the various machine statuses. This makes it possible to keep up-to-date on the current status of your profit CNC Machining Center.



Upper table extraction on the conveyor belt

The upper table extraction on the conveyor belt cleans the workpieces on the surface during transport. This guarantees that the labels will remain in place on the dust free surface.



Performance Control

With the performance package, the CNC control makes the highest industry standard possible. Different optimization levels ensure shorter process times, different milling results and increased comfort in CNC machining.

Increase of the maximum axis speeds by up to 30% in the X and Y directions.

Optimization of positioning and rotation speeds by up to 80% "Multitouch" function on the control terminal for user-friendly CNC machine operation Smooth, consistent and steady tool movements for best surface results on the finished workpiece. Reduced vibration behavior during CNC machining via the built-in jerk control

FORMAT 4®



Maintenance opening

For quick access to change the drill or maintenance work, the hood can be easily opened on all CNC machining centers.



Automatic labelling

The labeling system facilitates the work steps and guarantees absolute process reliability. The automatic pre-labelling on the loading table minimizes sources of error and at the same time reduces the processing times.

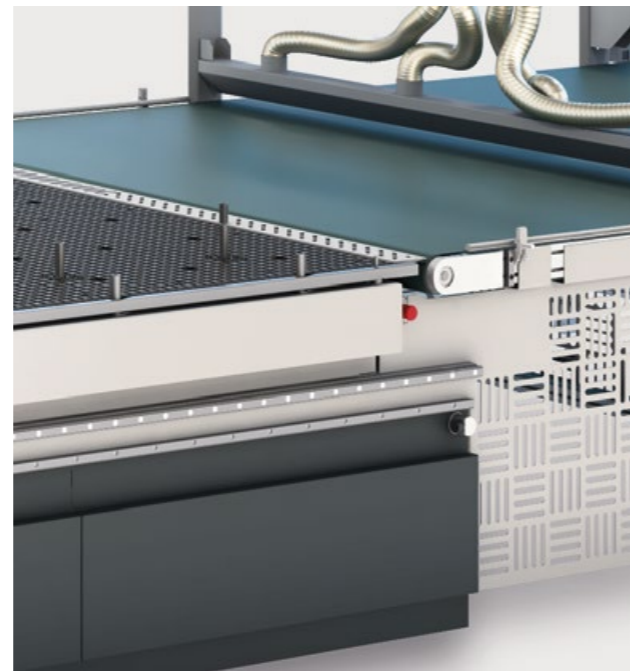

Under-table extraction

Final chips are completely extracted by the under-table extraction between conveyor belt and worktable.



Cover for linear tool changer

The cover optimally protects the high-precision HSK tool adaptors from dust and/or chips. Uneven running of the spindle due to dirt can therefore be excluded.



Panel lifting table

At automatic loading, the lifting table positions the stack of panels directly to the appropriate working height. The alignment of the panel materials takes place directly on the lifting table and synchronously for processing on the working area. This saves time and increases productivity.

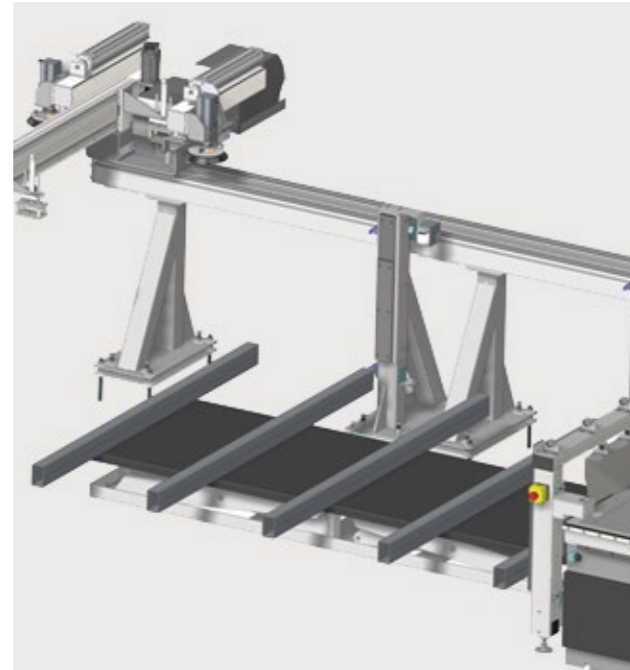

Individual automation options

The automatic labelling unit places the component labels in the correct position even before processing. This reduces sources of error and eliminates the need for additional work for the machine operator once processing has been completed.

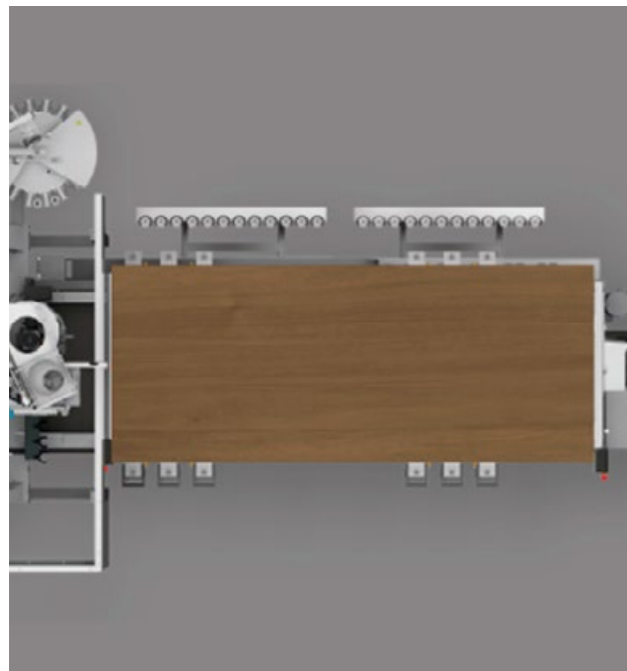

Free Working Area due to Hood Park Positioning

If the hood is in parking position, the entire working area is freely accessible. The machine operator therefore has no operational restrictions during workpiece positioning.



Short out-feed table

Thanks to its small footprint, the short out-feed table simplifies the removal of workpieces. An optional labelling unit can then be used to label the workpieces directly at the point of removal so that they can be identified in subsequent production processes.

Product range



Sliding Table Panel Saws



Shaper Spindles

Planers



Edgebanders



Wide Belt Sanding & Brushing Machines

Heated Veneer Presses



CNC Machining Centers



Nesting-CNC Machining Centers



Beamsaw Vertical saw



Vacuum panel lifter, Return systems & Feeding Units

FORMAT 4®

FORMAT4 Uncompromising expertise for the highest of requirements

The Felder Group premium brand has met the highest standards of professional users since 2001. The customized high-performance solutions are uncompromisingly innovative, offer maximum operating comfort and complete productivity.

FELDER GROUP

KR-Felder-Straße 1
A-6060 HALL in Tirol

☎ Tel. 05223 55306
www.format-4.us
[Contact](#)