

**FORMAT 4**®

**profit H200R**

HIGH-END CNC-TECHNOLOGY



**FORMAT 4<sup>®</sup>**

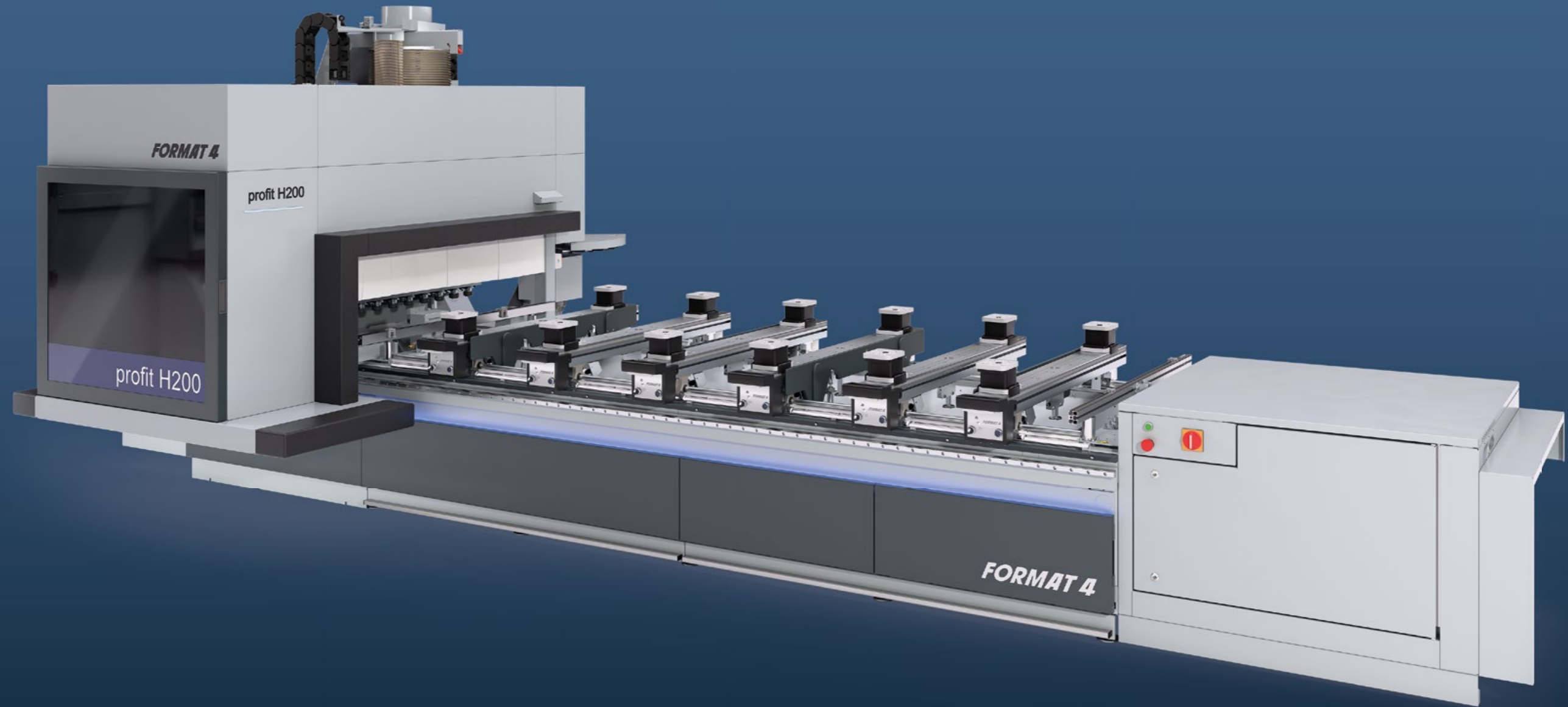

# High-end CNC technology at a low investment level



## profit H200R

- » Small footprint - minimal space requirement!
- » Drawing = programming, intuitive operating software
- » CNC software incl. 3D cabinet software "F4-Design" for presentations, parts list and connection to machine
- » Gantry design, solid construction for maximum performance
- » The drilling head covers the whole working field
- » High quality dual circuit vacuum clamping system with 100 mm vacuum pod height
- » F4®Solutions<sup>ready</sup>

Affordable CNC technology is becoming increasingly important, especially in the universal workshop. Whether conventional standard products or individually designed one-offs, the versatile Format4 CNC machining centers profit H200R and profit H300R produce both individual pieces as well as large batches with maximum efficiency, making them a real profit earner from day one.

## FORMAT4 Premium Machines for Premium Requirements

- |   |   |
|---|---|
| <ul style="list-style-type: none"> <li>» Constantly high performance in industrial continuous operation</li> <li>» Customer specific optimized production solutions</li> <li>» Solid design with premium components</li> <li>» Wide range of configuration packages with high-tech solutions</li> <li>» Complete engineering precision</li> <li>» Premium user comfort</li> </ul> | <ul style="list-style-type: none"> <li>» Quality and precision from AUSTRIA</li> <li>» Uncompromising productivity</li> <li>» Perfect service package before, during and after the purchase</li> <li>» Tailor made financing solutions</li> <li>» Mechanical engineering experience since 1956</li> </ul> |
|---|---|

# The most important highlights at a glance

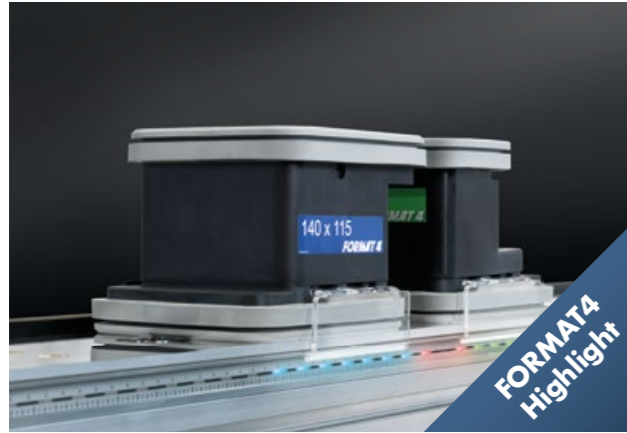

## lightPos – LED vacuum pods positioning, revolutionarily simple & precise

With lightPos, workpiece positioning during alternating operation is carried out without expensive set-up times. Top of the range comfort! Thanks to a sophisticated color management system, each vacuum type and its orientation is displayed in well-defined colours. RGB LEDs on the X-axis give information about the processing status. LEDs along the X- and Y-axis visualize the position and size of the workpiece.

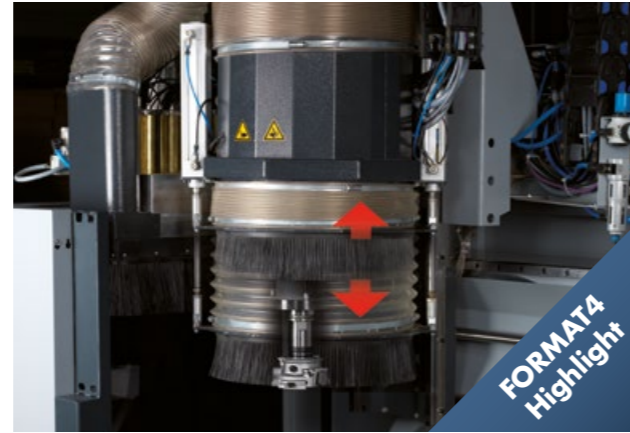

## Controlled extraction hood

The extraction hood positions itself fully automatically to one of 3 positions in relation to the workpiece height which significantly reduces the dust and noise emissions.



## 2-Circuit Vacuum Management

Thanks to the 2-circuit vacuum management on our consoles, the clamping devices are locked before the workpiece is positioned. The vacuum suction pads can therefore no longer be moved and process reliability is considerably increased.

# FORMAT 4®

## Details

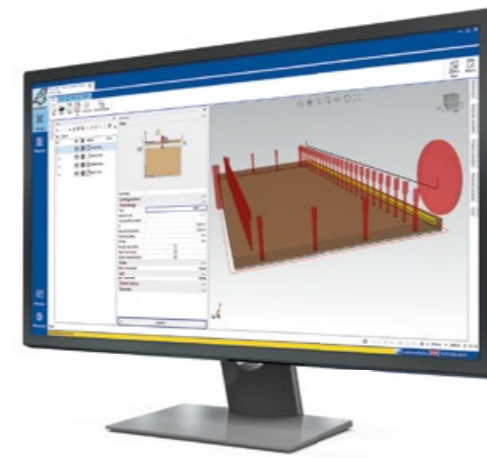

### F4®Integrate: The pioneering CNC software

For the highest demands, all inclusive - tool library, programming section and an operator control panel on the machine with a consistent and intuitive user interface. F4®Integrate is a software developed by Format4®. Developed from practical experience for practical use in cooperation with our CNC customers, F4®Integrate meets the highest demands in modern CNC machining.

Enjoy the comfort of a state-of-the-art and well-coordinated user interface. Tool library (F4Toolbox), programming section (CAM area with integrated CAD area, F4Create) and machine operation control (F4Operate) all packed into just one single screen, with a consistent and intuitive user interface.

F4Integrate is based on G-Code, so external industry programs can be easily connected and the transfer of programs smoothly organized.



### Rows of stops

For this purpose, the H200 series is equipped with rear and center fence rows. The solid cylinder stops allow flexible component referencing of small, medium and large workpieces on the work area.



### Maintenance opening.

For quick access to change the drill or maintenance work, the hood can be easily opened on all CNC machining centers.



#### Flexible and unrestricted use of clamping devices

A variety of vacuum pod shapes guarantee the secure positioning of any kind of workpiece shape. In addition, the number of vacuum suction pads and clamping devices can be used flexibly on the entire console without restriction.



#### Frame processing

Not only vacuum suction pads but also frame clamping devices can be used for the processing of frame components. In contrast to vacuum suction pads, frame clamping devices use compressed air to generate their clamping force. This allows a significantly higher clamping force to be achieved. The compressed air connections are located on the bottom of the console.

## FORMAT 4®

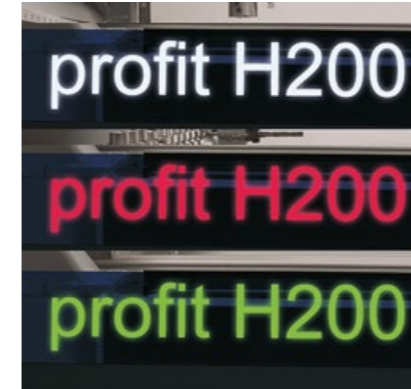

#### Status display

The changing colors of the innovative lighting system display the various machine statuses. This makes it possible to keep up-to-date on the current status of your profit CNC Machining Center.



#### Workpiece loading supports

Loading supports assist in the simple loading and unloading of large or heavy workpieces. A major advantage is that they enable you to operate the machining center with one person.



#### Template milling

There is a separate connection available for template routing. Using templates makes it possible to fix complex components in place, that cannot be processed using vacuum pods.



#### Position display of the workpiece supports and vacuum pods

In the standard configuration, the workpiece, the workpiece supports and the vacuum suction pads are displayed simultaneously on the CNC board. This guarantees, that the workpiece is securely positioned and that there can be no collision between the tool and vacuum pod. The exact position of the vacuum pods on the consoles is shown using a laser. The lightPos system is available as an extension to our standard positioning aid.

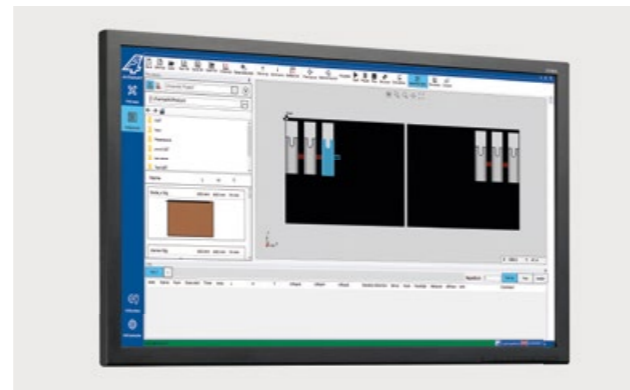

#### Intuitive touch-screen control on a 24" monitor

The advanced and intuitive touch-screen control concept guarantees maximum user friendliness. The clearly structured and self-explanatory user interface allows you to operate the machine with ease and ensures maximum productivity. The machine controls are clearly displayed graphically and various programs, set-points and commands can be executed quickly, easily and accurately at the touch of a button.



#### Console activation

Specially designed for use with compressed air controlled frame clamp systems, this function offers new possibilities and enormous clamping strength when it comes to the processing of solid wood. The ability to be able to deactivate the consoles individually makes it possible to remove offcuts without having to release the vacuum that is holding the workpiece. This ensures that the workpiece stays in exactly the right position for the next working process (inner profiles etc.).



#### Workpiece stop for veneered panels

Additional to the workpiece fence cylinders there are also separate fences available for the processing of veneered surfaces with a projecting edge or laminated panels.



**Spindle**

With a motor power of 12 and 15 kW and up to 24,000 rpm, the main motor is controlled using an inverter and is attached directly to the support module of the drilling head in the Z axis. Dual linear guides guarantee highly precise vertical guiding. The main motor is positioned using ground ball screws. The HSK F63 tool clamping is done automatically. The clamping of the tool is checked using sensors, which then confirm that it is safe to start the operation. The tool holder is cleaned automatically. The C-axis is optionally available as the fourth axis and is interpolating (360°) with a compressed air interface for the units.

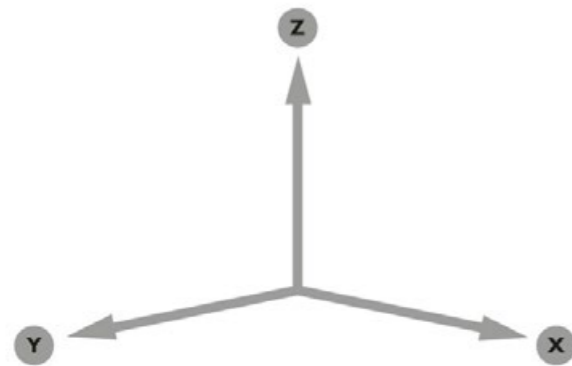

**Working area sizes**

Working area: X=10 ft 9 59/64 in (3300 mm), Y= 4 ft 2 25/64 in (1280 mm), Z= 9 27/32 in (250 mm) (clearance height starting from bracket height)



**Chip deflector**

A chip deflector mounted to the spindle controlled by the C-axis enables the unrestricted use of existing tools. When processing workpiece edges, the dust and chips are directed towards the extraction canal.

**FORMAT 4®**

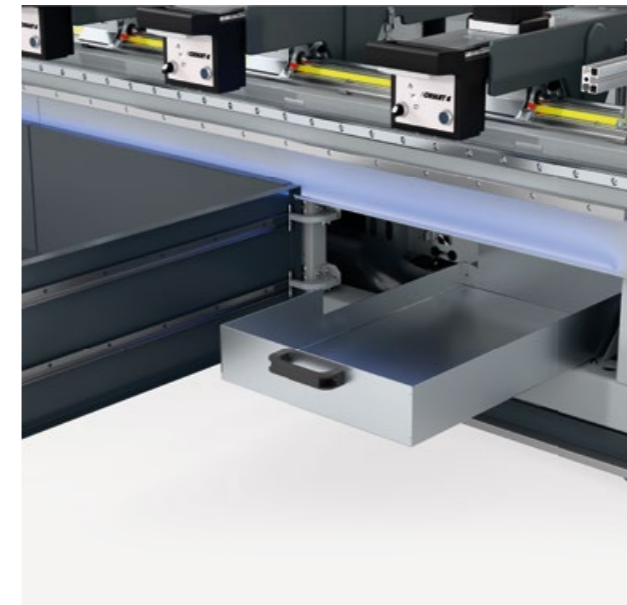

**Chip conveyor**

Chip conveyor for waste pieces and residual chips and dust: For the removal of offcuts and chips from the machine chassis (right hand side). At the end of the conveyor or belt they are separated using a separating slide and then extracted. The offcuts are collected in a container.

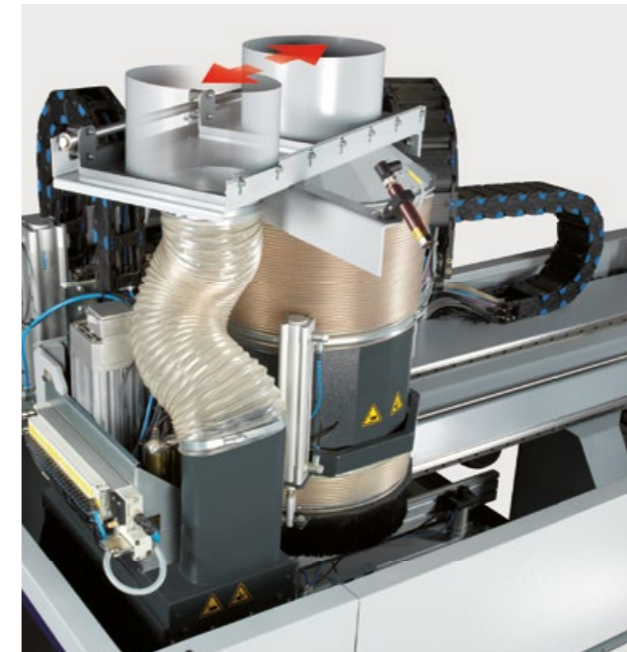

**Extraction connection**

With the automatic control of the extraction connection, the full extraction capacity is moved between the drilling head and main spindle, depending on what is being used at the time.



**Compressed air nozzle/spraying unit**

Mounted onto the main spindle to optimize routing. Comfortably controlled with solenoid valve directly with the control software.



**Longitudinal measurement system**

The automatic length measuring unit determines the tool length with an accuracy of one hundredth of a millimeter directly within the machine. This eliminates measuring errors by the machine operator.



**12-position linear tool changer on the left side of the machine stand**

The 12-position linear tool changer on the left side of the machine stand also offers the option of storing up to 3 units. In addition, the frontmost unit storage position can be used as a pick-up station for hard-to-reach tool changing stations.

The cover optimally protects the high-precision HSK tool adaptors from dust and chips.

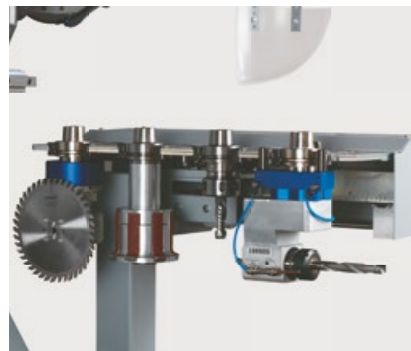

**4 position linear tool changer moving in the X-axis direction**

Tool changer for 4 tools or aggregates, mounted to the gantry. Ensures quick tool changes even when working in pendulum operation.

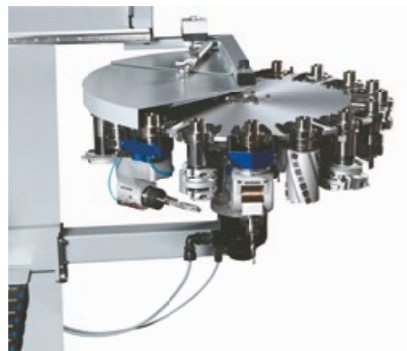

**18 position rotary tool changer mounted to the outrigger**

The rotary tool changer with 18 tool positions is mounted to the back of the gantry and moves together with the gantry along the X-axis. The 18 position rotating tool changer, keeps tool changing times to the bare minimum.



**12-position linear tool changer on the right side of the machine stand**

The tool changers with 24 tool positions increase productivity and create more space for additional tools on the machine.

# FORMAT 4®

**3D simulator with collision control**

The 3D simulator accurately displays travel distances, feed speeds, travel heights, and optional equipment such as the 5-motion unit, the chip deflector, all rotary tool changers, or drill heads, and determines precise working times. The collision check tests whether any collisions could happen and guarantees the working safety on the machine. Through the allocation of the tool DXF profile, the contour of your router can be shown on the workpiece. Even when calibrating new tools, the DXF profile can be used which helps to reduce the amount of material use.

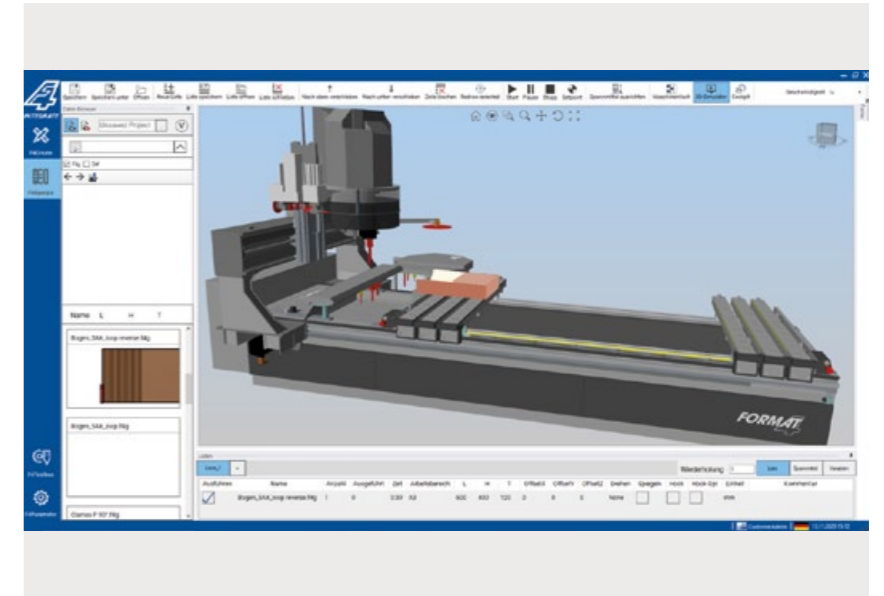

**Automatic central lubrication system:**

The lubrication is applied as and when required to the guide carriages of the X, Y and Z axis as well as the bearing spindles in Y and Z. Lubrication is carried out automatically after a preset time.

**Linear guides**

**X-axis guiding system:**

Positioning is carried out by recirculating ball bearings running along hardened and polished linear guides. The X-axis is positioned via a cambered rack and pinion gear.

**Y- and Z-axis guiding system:**

Positioning is carried out by recirculating ball bearings running along hardened and polished linear guides. The Y- and Z-axis is positioned by a polished recirculating ball spindle.

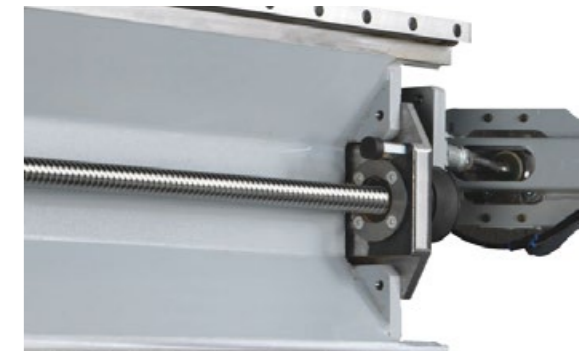

**Free Working Area due to Hood Park Positioning**

If the hood is in parking position, the entire working area is freely accessible. The machine operator therefore has no operational restrictions during workpiece positioning.

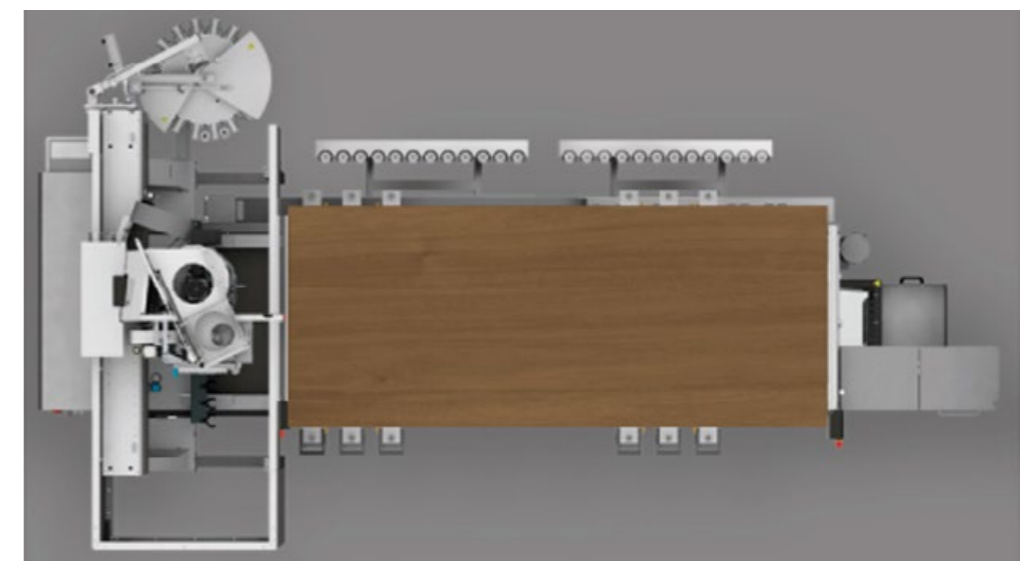



**Safety Concepts can be Freely Selected.**

In order to be able to offer our customers different advantages (user-friendliness, productivity, space requirement,...), the machine is available with several safety concepts:

- » Light barrier
- » Foot mat
- » Bumper

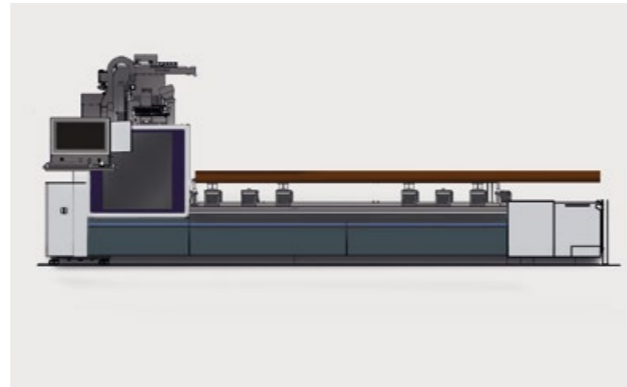

**Flexible Processing of Extra-Long Components**

Tool changer and control cabinet are located below the zero level of the working area. This allows extra-long components to be flexibly clamped and processed in two steps.



**100 millimeters Suction Pad Height**

Our machines are equipped with vacuum suction pads of 3 15/16" in height. Because of the increased distance between the console and the workpiece, the machining restrictions on the workpiece underside are significantly minimized, as well as when using aggregates on the lateral surfaces.



**Comfort Footswitch Bar**

At the front of the machine, a foot switch bar is integrated in the pedestal along the entire length of the working area. This eliminates the need to search for or move the foot pedal during workpiece positioning. The simple construction blends into the coherent design of the machine.

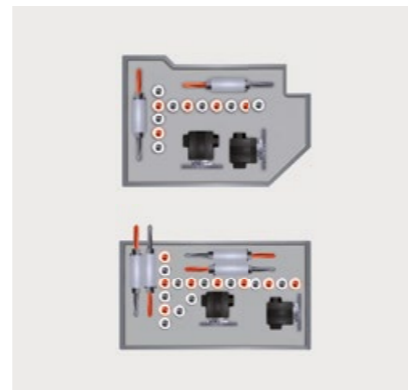

**Individual drill head configuration**

Regardless of whether the machine will only be used for cabinet manufacturing or as an all-rounder, you can decide which drilling head configuration is the right one for you. Choose the drill head that suits your processing needs from our extensive range! Inverter controlled motor up to 7500 rpm

**Product range**



Sliding Table Panel Saws



Shaper Spindles

Planers



Edgebanders



Wide Belt Sanding & Brushing Machines

Heated Veneer Presses



CNC Machining Centers

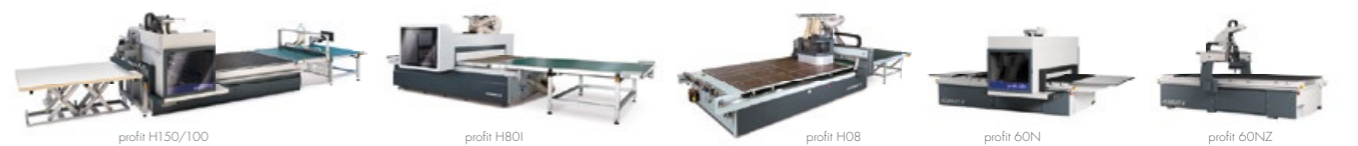

Nesting-CNC Machining Centers



Beamsaw Vertical saw



Vacuum panel lifter, Return systems & Feeding Units

# ***FORMAT 4***®

## **FORMAT4 Uncompromising expertise for the highest of requirements**

The Felder Group premium brand has met the highest standards of professional users since 2001. The customized high-performance solutions are uncompromisingly innovative, offer maximum operating comfort and complete productivity.

### **FELDER GROUP**

KR-Felder-Straße 1  
A-6060 HALL in Tirol

☎ Tel. 05223 55306  
[www.format-4.us](http://www.format-4.us)  
[Contact](#)