

***FORMAT 4***®

**kappa 590**

MITRE CUTTING IN  
ANY POSITION

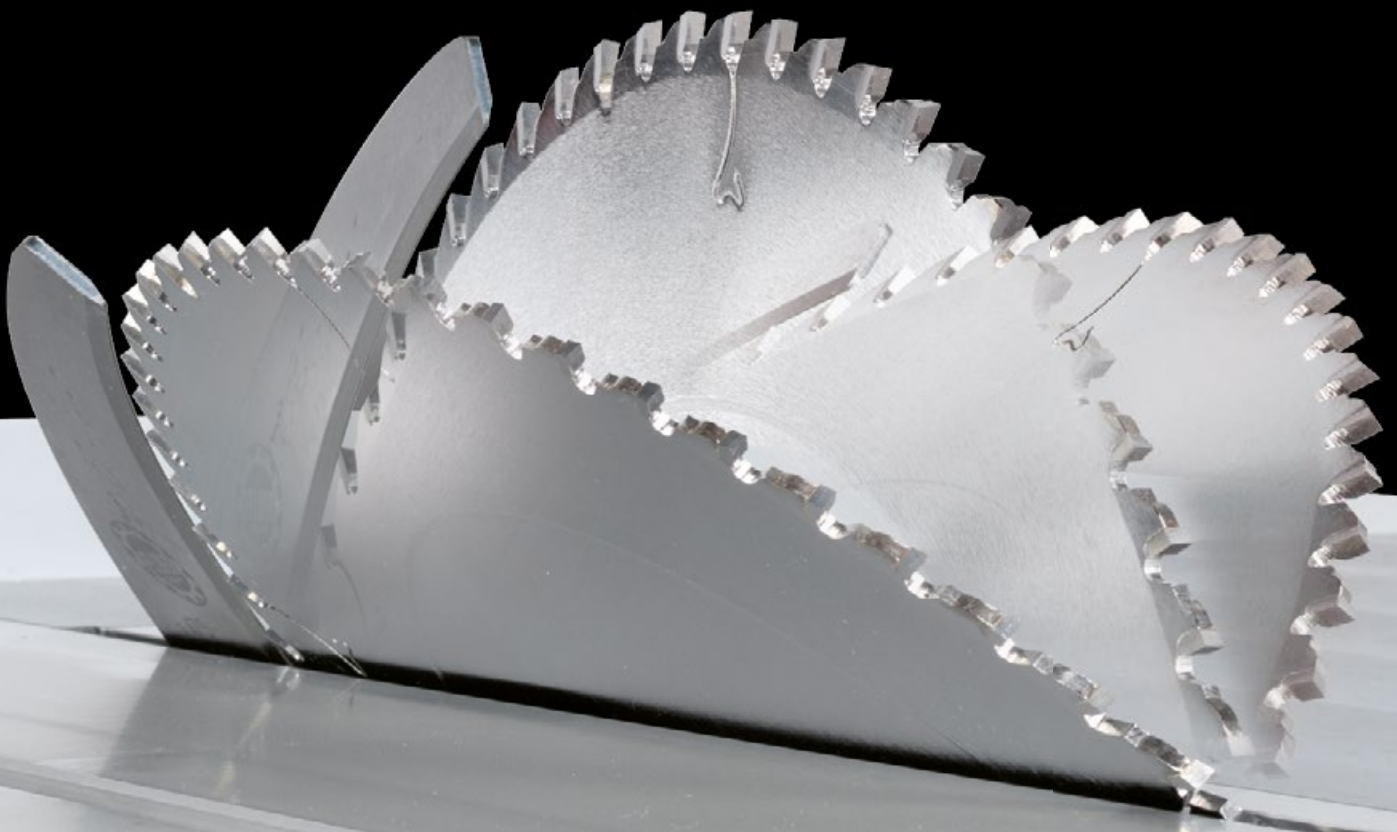

**FORMAT 4.**<sup>®</sup>

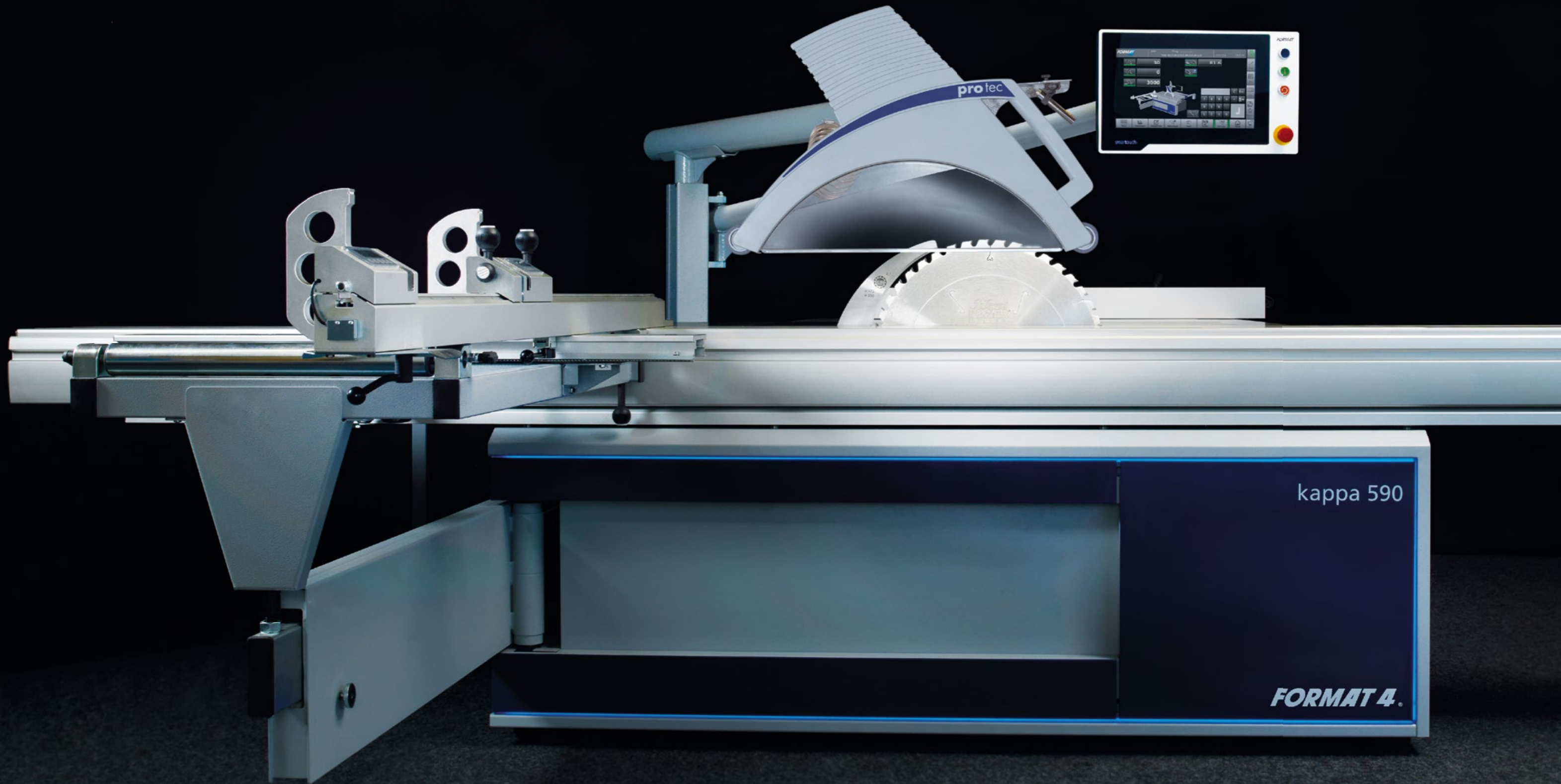

kappa 590

**FORMAT 4.**

## The ingenious panel saw with double pivoting for angle cuts in all positions



With innovative features, the new kappa 590 has become the new benchmark for premium sliding table panel saws. The new twin-pivot unit has a total pivot range of 92° and achieves a cutting height of 202 mm for saw blades with a diameter of 550 mm. This saves valuable working time and simplifies the cutting of internal mitre and simple compound cuts.

The highly efficient synchronous motor with continuously adjustable speed control from 2,000 to 5,000 rpm guarantees constant high performance and best power transmission with state-of-the-art Poly-V-belt technology.

All axes of the machine can be controlled ergonomically and intuitively by the central operating unit with 15" touch screen. The in-house software with graphical user interface, a multitude of programs, a USB interface and the prepared network connection make work easier and guarantee efficiency and productivity.

The c-tech product line offers specially designed equipment options for processing plastics and composite materials.

It goes without saying that the new premium sliding table saw comes with all the tried-and-tested Format4 advantages and quality features. With these Format4 system solutions, different outrigger versions, and individual control options, the kappa 590 sliding table panel saw turns perfection into the norm!

### Variations

Models & Your Advantages



#### kappa 590 e-motion

- » Double pivoting +/- 46°
- » Cutting length: 800–2.050 mm
- » X-Roll sliding table, 10 year guarantee
- » Rip capacity: 800–1.250 mm
- » Cutting height 202 mm
- » e-motion control
- » ∞ program spaces + ARDIS cutting optimisation



#### kappa 590 x-motion

- » Double pivoting +/- 46°
- » Cutting length: 800–2.050 mm
- » X-Roll sliding table, 10 year guarantee
- » Rip capacity: 800–1.250 mm
- » Cutting height 152 mm (optional 202 mm)
- » "x-motion" control

### FORMAT4 Premium Machines for Premium Requirements

- » Constantly high performance in industrial continuous operation
- » Customer specific optimised production solutions
- » Solid design with premium components
- » Wide range of configuration packages with high-tech solutions
- » Complete engineering precision
- » Premium user comfort
- » Quality and precision from AUSTRIA
- » Uncompromised productivity
- » Perfect service package before, during and after the purchase
- » Tailor made financing solutions
- » Mechanical engineering experience since 1956

# The most important highlights at a glance



## Intuitive „smartouch“-control with touchscreen

The central operating unit with touch screen provides ergonomic and intuitive control of all the machine's axes. The in-house software with graphical user interface, a multitude of programs, a USB interface and the prepared network connection make work easier and guarantee efficiency and productivity. The USB interface for importing and exporting data is prepared for network connection and remote maintenance.

Additional functions and cutting programmes: rebates, grooves, notches, angle cuts, oblique cuts plus, false mitres, compound cuts plus, concealed V-neck, hip and valley rafters.



## Masterpiece sliding table – unrivalled precision and smoothness!

Large dimensioned and designed with the highest use in mind, the aluminium format sliding table "hovers" on the "X-Roll", a highly developed, state-of-the-art guiding technology for Format4 sliding tables. The X shape ("X-Roll") design of the rollers distributes the load optimally on all sides. The linear surface of the steel rollers running on the hardened and ground guiding surface guarantees unbeatable precision and smoothness. "X-Roll" will guarantee you the quality and precision that you expect from your new panel saw. And here's another reason why one should opt for Format4: a 10-year factory warranty emphasises the reliability of the „X-Roll“ guiding system.



## Double pivoting of the circular saw blade +/-46°

The Format4 innovation forge highlight: the new double pivoting saw unit. Pivoting in both directions (+/- 46°) allows a completely new dimension in working with the panel saw:

- » Mitre cut of frame parts with continuously overhead visible side
- » Complex compound cuts
- » Grooves in a miter
- » and many more

# FORMAT 4®

## Details



## Control extension "e-motion plus"

Upon request, the "smartouch" machine control system can be extended with numerous other programs for geometric functions: knee bar, parallelogram, trapezoid, polygon, staircase, triangle, pyramid, cuboid, slots / tenon, corner bench rest.



## Video tutorials: Preset cutting programs

Every cut with the Format4 sliding table saw is a masterpiece of precision. For example, when cutting a pyramid, which is one of 18 predefined cutting programs.

Rabbets, grooves, notches, wrong mitre, rafter cut and various geometric shapes, in short videos we show you how it works: Enter workpiece shape and workpiece dimensions on the touch screen, follow the visual cutting plan – done.

*\*Please note that some of the cutting programmes shown are not possible on machines without double tilt.*

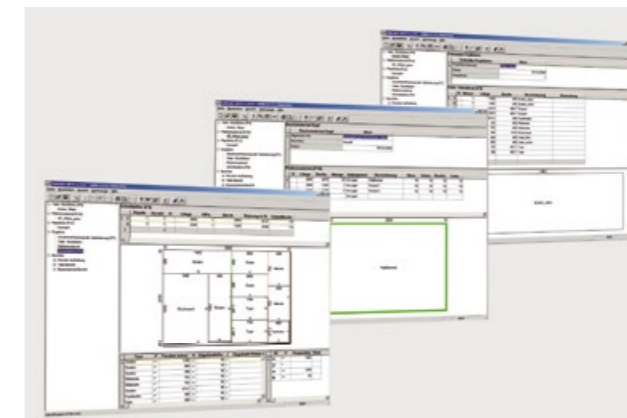

## Ardis Cutting Optimisation Software

Thanks to the integration of the Format4 cutting optimisation programme into the machine and operating concept, all work steps can be carried out efficiently and quickly from one central location. Thanks to the easy handling and the clear, user-friendly display, no training is necessary.



## Label printer

Not only does the label printer enable the workpieces to be labeled correctly, it also enables a logical post-processing. For example, programs for successive work processes on CNC machines and edgebanders will be imported from the barcode scanner. Save valuable production time with the label printer and increase productivity, quality and as a result, your profit.



**The new TOP circular saw unit 590**

The newly developed Format4 TOP-unit offers maximum power and precision with extremely smooth operation. The double-mounted circular saw shaft in solid cast iron housing guarantees absolutely vibration-free working at maximum performance.

- » Saw blade double pivoting +/-46°
- » 3-axis "Control" scoring unit
- » Scoring unit park position
- » Sensational: saw blade change without tools
- » Big cutting height: 202.0/140.8/118.7 mm (90°/+45°/-45°) – (optional with x-motion)
- » Spraying unit for processing non-ferrous metals and plastics
- » Tilt segment „Easy-Glide“ for circular saw unit



**Spraying unit for processing non-ferrous metals and plastics**

For the machining of non-ferrous metals or plastics, your Format4 can be equipped with a spraying unit. High performance lubricating oil can be sprayed directly onto the saw blade, transported via piping from the spraying unit.

**Synchronous motor with continuously adjustable speed control**

The highly efficient synchronous motor provides maximum torque with high efficiency. Quick and easy selection of the optimum rotating and cutting speed via the machine control.

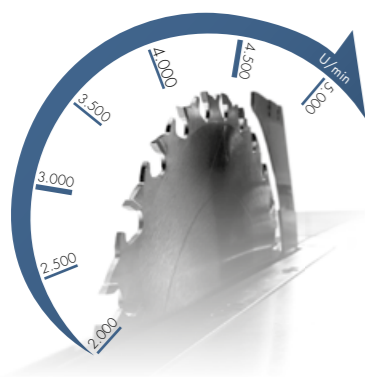

**Easy Glide – 6 year warranty!**

- » Precise double trunnion system
- » High load-bearing capacity and operating life
- » Play-free tilt
- » Unaffected by dust
- » Completely maintenance free
- » No lubrication required
- » 6 Year Guarantee



**Big cutting height**

With the new kappa 590, you can cancel the cutting height limit in your workshop. 202,0 mm at 90°, 140,8 mm at 45° and 118,7 mm cutting height at -45°, these are the new standards in the class of premium panel saws!



**Tool-free saw blade change „Easy-Lock“ – only with Format4!**

The clamping system is completely maintenance-free and offers premium comfort for many years: Effortlessly change saw blades and riving knives literally in the blink of an eye.



**Simple, safe & quick – "Quick-lock" saw blade clamping**

Quick and easy blade change with only one tool, thanks to the „Quick-Lock“ system.



**3-axis "Control" scoring unit**

The scoring unit blade width and height adapt automatically to the stored tool information and also to the respective teeth width of the main saw blade. Any changes to these standard scoring settings can be saved and retrieved when using the same tool in the future.

**Scoring unit park position**

The scoring blade no longer needs to be removed when using a larger saw blade. The new Format4 „parks“ the scoring unit at the touch of a button, which frees up space for large saw blade diameters and saves you valuable production time! Additionally the park position also protects the scoring blade from resin.



**Safety made visible - Scoring unit operation display**

A red LED strip immediately signals the operation of the scoring unit and offers even more working safety. (Option)

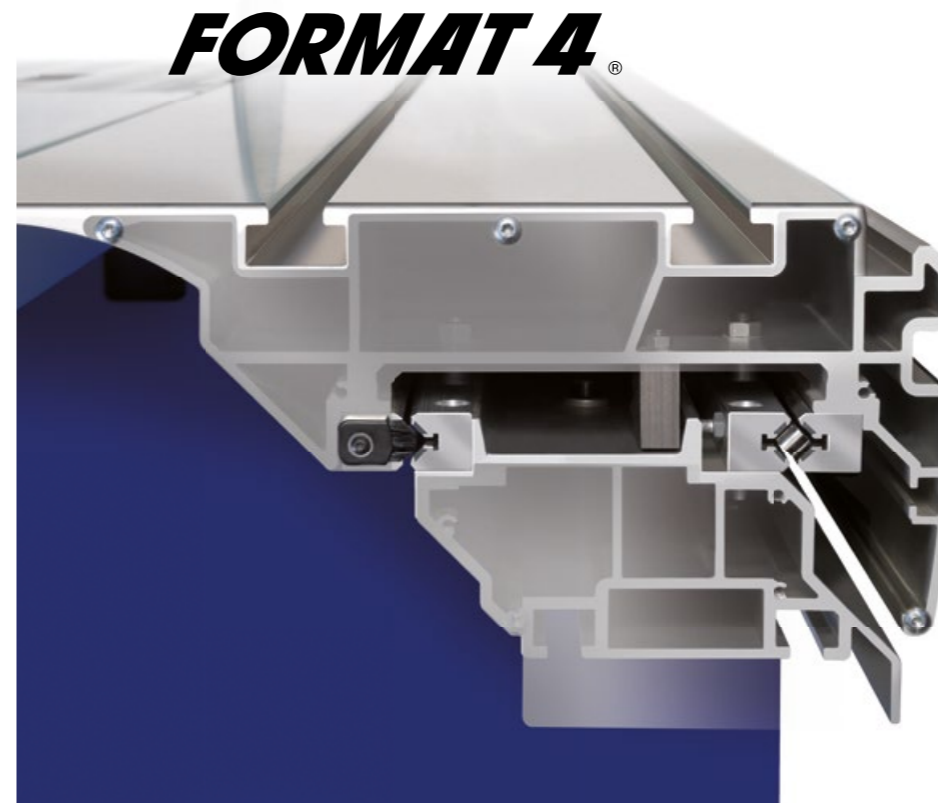

**“A masterpiece of engineering”,  
guarantees precision and smooth operation!**

Large dimensioned and designed with highest use in mind, the aluminium sliding table “hovers” on the “X-Roll”, a highly developed, state-of-the-art guiding technology for Format4 sliding tables. The X shape (“X-Roll”) design of the rollers distributes the load optimally on all sides. The linear surface of the steel rollers running on the hardened and ground guiding surface guarantees unbeatable precision and smoothness. “X-Roll” will guarantee you the quality and precision that you expect from your new panel saw. And here's another reason why one should opt for Format4: a 10-year factory warranty emphasises the reliability of the „X-Roll“ guiding system.



**Fix in every position – Multiple position locking of the sliding table**

The tried and tested “X-Roll” sliding table with linear guide system is now equipped with a stainless steel latch plate which enables the sliding table to be locked in almost any position.



**Remote “ON”-switch on Format sliding table.**

On demand, you can increase user-friendliness and shorten working distances with the ON and OFF buttons directly on the Format sliding table.



**The electronic double cut mitre gauge**

A valuable accessory in daily use of sliding table saws is the patented Format4 electronic double mitre gauge. It allows mitre cuts of workpieces of different widths at any angle. Over the keyboard of the integrated computer the workpiece widths A, B and the the desired frame angles are entered. The results are shown on the display with an accuracy of a tenth of a degree. Just set the double mitre gauge to the calculated value and start working immediately, the end result is accurate to a tee! The crosscut fence stops on the fence guides can be adjusted up to 1.350 mm using the scale. The vernier scales compensate for the length, allowing you to set and cut the exact required length.



#### Quick customizable overhead saw guard

The handling of the overhead saw guard is simple and comfortable. The moveable extraction hood can be easily adjusted for pivoting in both directions without having to replace the hood.



#### Overhead saw guard with below table extraction

The newly developed overhead saw guard and under table extraction system deliver perfect extraction results. The overhead saw guard with its distinctive design is easily adjustable in height over linear guides. The dust and shavings are sucked from the saw guard into the extraction pipe via a short hose. The below table extraction system encloses the entire saw unit. In terms of extraction technology, the chip duct is perfectly shaped, and an optimised chip flow from the scoring unit also ensures absolutely perfect extraction results.



#### Remote lock release

In one movement, the overhead saw guard can be unlocked and swung completely out of the machine table area. If required, the overhead saw guard can be unlocked directly using a lever on the cover.

## FORMAT 4®

#### Crosscut fence (outrigger)

The outrigger crosscut fence allows you to perform crosscuts up to 3.200 mm. Even the standard version already provides you with top-class technology and comfort. The scale that is tilted towards the operator and the lens on the crosscut fence guarantee precise settings.



#### Digital and accurate to a tenth of a millimetre

On request, we can equip your Format4 with a digital outrigger crosscut fence. The stylish integrated electronic digital display shows the adjustment accurate to a tenth of a millimetre. Additional functions, such as the adjustment of chain dimensions, simplify your daily work.



#### "digi-compensation plus" – digital angle/length compensation

The digital angle and length compensation module "digi-compensation plus" for X-roll or parallelogram outrigger tables compensate any changes in the length difference of the crosscut fence settings, as the angle is changed. The direct communication with the controls, also enables it to compensate the fence position of the crosscut stop to the width of the tooth and the tilt of the saw blade. This ensures that you always get an exact measurement without any recalibration when using different saw blades.

**“X-Roll” outrigger table**

Outrigger table supported by 8 ball bearings, integrated guide rollers and bearings for maximum smooth running at the highest loads. The finely adjustable support rail runs on high-precision and maintenance-free „X-Roll” rollers and provides a large support surface even if the outrigger table is swivelled. It is possible to set the angle to an accuracy of 1/100° using the digital display. The continuously variable tilt range between -45 and +45 ensures precise mitre cuts.

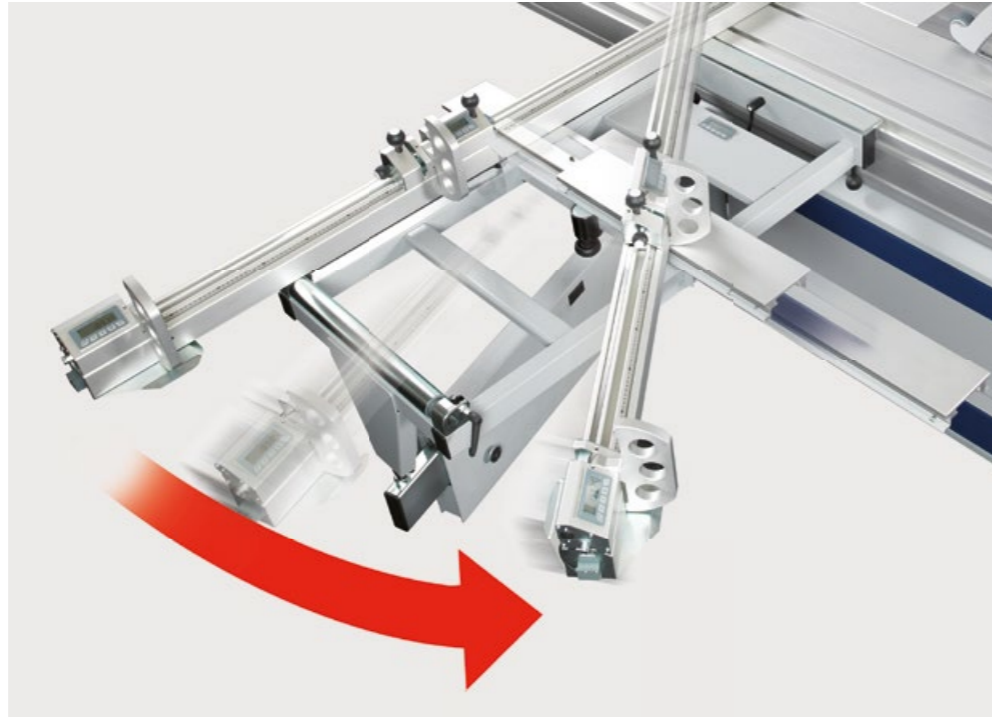

**Parallelogram outrigger table**

Continuously variable adjustment range -45 bis +45° It is possible to set the angle to an accuracy of 1/100° using the digital display. Angle-length compensation via Nonius, for automatic fence via control.

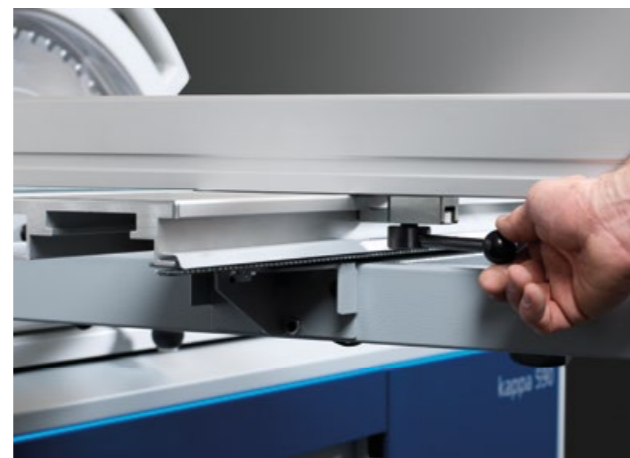

**Even more flexible – Ergonomic locking lever at the crosscut fence**

The crosscut fence on the outrigger table can be easily and quickly tilted variably from zero to 45°. The large dimensioned, ergonomic clamping lever can be used at every angle.

**FORMAT 4®**

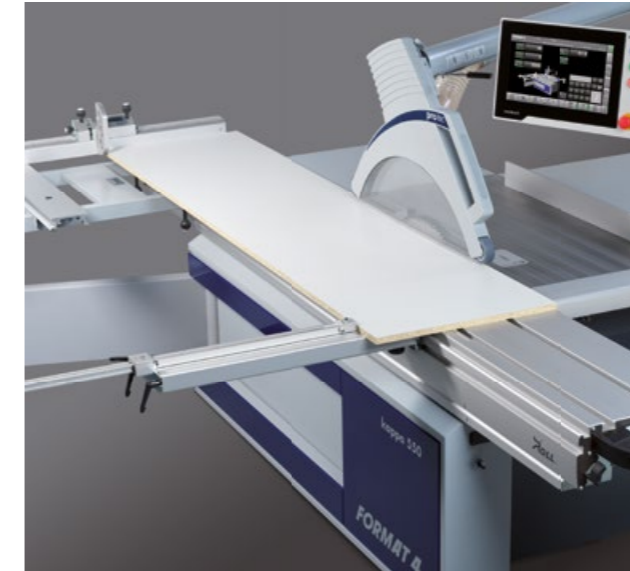

**Rip fence for “X-Roll” sliding tables**

The ideal accessory for rip cuts on the sliding table! You use the support surface of the sliding table and outrigger in combination with the rip fence and in doing so guarantee perfect support of the workpiece to be processed. The rip fence is attached to the sliding table, the integrated scale from 25-1,000 mm can be read easily using the integrated magnifying glass.

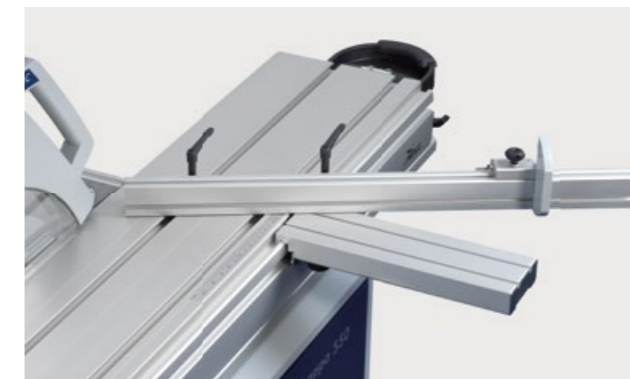

**The crosscut fence on the format sliding table**

The crosscut fence is adjusted for mitre cuts between +45° and 45° using the mitre index scale integrated in the format sliding table. The T-slot and lateral holders on the format sliding table allow for quick assembly without tools. The scale facing the operator and the read-out lens on the fence stop ensure precise settings up to 1,100/2,050 mm.

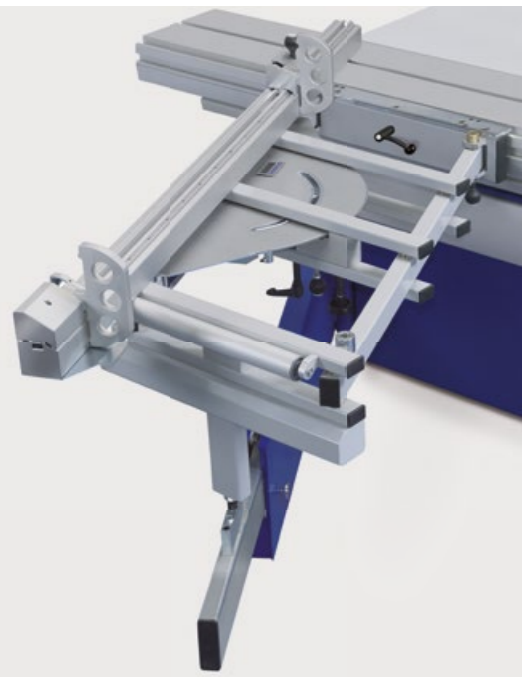

**Full surface support on the outrigger table**

The new full surface and magnetic mounted supports on the outrigger table offer an increased support surface and guarantees a safe grip and a stable support for the processing of smaller workpieces.



**Transport and mounting unit for outrigger table**

At last: Quick, comfortable and effortless, removal and mounting of your outrigger table using the transport and mounting unit. And another positive aspect: your outrigger can be conveniently stored away!

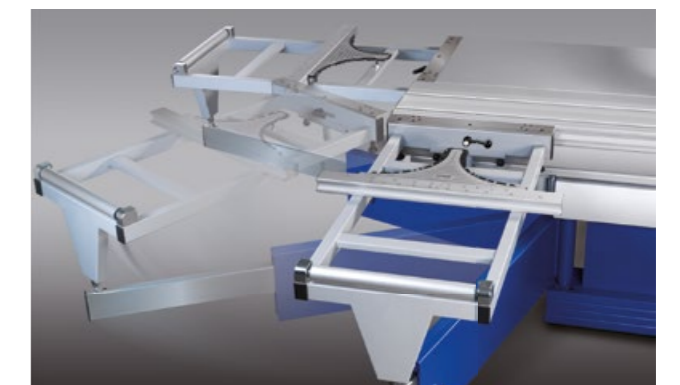

**Highlight – Parking the Outrigger**

The outrigger table can be swung out of the way with ease! No more complicated mounting and removing of the outrigger table. The swing away device ensures first class operating comfort while saving on valuable workshop space. Back-friendly ergonomic work is also guaranteed.



#### Electronic digital display

The rip fence can be equipped with an electronic digital display. The perfect integration of the whole electric unit makes it possible for you to rotate the display by 90°, and as such the settings can be read from the operator side in every rip fence position. Additional functions such as the use of incremental cuts also help to make day to day work easier. More Highlights:

- » Easy to read values, with a bright, red LED display
- » No batteries required as it is connected to the power supply of the machine
- » Automatic recognition, whether the fence is in the vertical position or laid flat
- » Compensation for the tooth width of the saw blade



#### Parallel fence with positioning control

The rip fence is positioned by a motor and runs via a dust-free integrated ball spindle in the saw table. The 1/10 mm precision, the high positioning speed, as well as the simultaneous positioning of the crosscut fence, saw blade height and saw blade angle ensure precision and save valuable working time.

- » Optional for standard and x-motion-models
- » Standard with e-motion-models



#### Pneumatic workpiece holder

- » Easy clamping of workpieces with maximum flexibility. Can be used on all panel saws and spindle moulders that are equipped with a sliding table.
- » Easy set up due to magnetic fittings
- » Safety cylinder ensures maximum working security
- » Pressure bar function is possible with every sliding table length
- » Clamping height 95 mm
- » Clamping force approx. 300 kg

## FORMAT 4®



#### Always at hand & clearly visible - front tool compartment with LED

Upon request, we will equip your kappa with LED lighting and an integrated tool compartment for 4 saw blades with a max. diameter of 400 mm, 1 saw blade with a max. diameter of 550 mm plus 2 riving knives.



#### Parts list holder with clipboard

The convenient parts list holder with A4 clipboard is mounted on the overhead control panel, keeping your parts lists in sight at all times.

## Technical specifications

Electrics		kappa 590 e-motion	kappa 590 x-motion
001	3x 400 V motor voltage	S	S
004	50 Hz motor frequency	S	S
005	60 Hz motor frequency	W	W
006	Motor 7.5 kW S6, with infinitely variable speed 2.000-5.000 rpm		S
007	Motor 10 kW S6, with infinitely variable speed 2.000-5.000 rpm	S	O
008	Motor 14 kW S6, with infinitely variable speed 2.000-4.000 rpm	O	O
12	Switch contact for the control of an extractor	O	O
<b>Panel saw drive</b>			
71	Tool compartment with LED machine lighting	O	O
72	Circular saw with table extension up to 1.620 mm behind the saw axis, anodised aluminium	O	O
73	Spraying unit for processing of light metals and plastics (!1.000)	O	O
76	Scoring unit aggregate "Control" with 3 controlled axes (height, width, lateral offset) and park position, 1.1 kW, scoring saw blade-Ø 150 mm in combination with max. saw blade-Ø 400 mm, adjustment range 3.0-3.8 mm, max. saw blade-Ø in park position 550 mm	O	O
78	"Easy-Lock" – Tool free quick change system for the main saw blade and riving knife adjustment, drive pins in the flange prevent it from twisting, can be retrofitted to all kappa 590 models	O	O
780	"Quick-Lock" – Quick change system for the main saw blade and riving knife adjustment, drive pins in the flange prevent it from twisting	O	O
79	Scoring unit status light	O	O
-	Saw table with table extension up to 1.200 mm behind the saw axis, powder coated steel	S	S
-	Position controlled height adjustment;	S	S
-	Position controlled angle adjustment +/-46°	S	S
-	Saw blade diameter 300-450 mm, cutting height max. 152 mm (# 006)		S
-	Saw blade diameter 300-550 mm, cutting height max. 202 mm (#007/008)	S	O
<b>Control systems</b>			
100	Software package e-motion plus	O	
26	Plug connection for the removal of the overhead saw guard and overhead control panel	O	O
-	e-motion control system with touch function in control panel installed at eye level; USB interface and preparation for network connection; The panel can be positioned optimally in the working area of the operator and be completely swung away if necessary	S	
-	x-motion control system with touch function in control panel installed at eye level; USB interface and preparation for network connection; The panel can be positioned optimally in the working area of the operator and be completely swung away if necessary		S

Safety devices		kappa 590 e-motion	kappa 590 x-motion
81	Remote unlocking to allow the saw guard to be swung away	O	O
-	Adjustable overhead guard for +/-46, height adjustable hood for 90° and hood for mitre cuts, which can be swung away from the working area.	S	S
<b>Cutting width and parallel fence</b>			
83	Cutting width 1.250 mm, anodised aluminium;		O
84	Cutting width 1.600 mm, anodised aluminium		O
85	Digital display for parallel fence with automatic cutting width compensation when the saw blade is tilted.		O
88	Position controlled rip fence with digital display on the control panel at eye level, 1.250 mm rip capacity	S	O
89	Position-controlled rip fence with digital display at eye level on the control panel, cutting width 1.600 mm	O	O
891	Position controlled rip fence with digital display on the control panel at eye level, cutting width 1.000 mm	W	O
-	Parallel fence with fine adjustment, fence length 1.200 mm, can be swung away		S
-	Cutting width 1.000 mm, powder coated steel		S
<b>Anodised sliding table, "X-Roll" guiding system</b>			
130	"X-Roll" format sliding table, cutting length 2.200 mm, edging shoe	W	W
131	"X-Roll" Format sliding table, cutting length 2.800 mm, edging shoe	S	S
132	"X-Roll" Format sliding table, cutting length 3.200 mm, edging shoe	O	O
133	"X-Roll" Format sliding table, cutting length 3.700 mm, edging shoe	O	O
134	Multiple locking mechanism on the sliding table (!130)	O	O
139	On and off switch on the sliding table	O	O

Outrigger tables and crosscut fences		kappa 590 e-motion	kappa 590 x-motion
160	1.250 x 650 mm outrigger table	S	S
161	The 1.250 x 650 mm "X-Roll" outrigger table with moveable support rail and digital angle display	○	○
162	1.250 x 650 mm outrigger with parallelogram adjustment and digital angle display (!133)	○	○
164	Extendable frame for outrigger with workpiece roller up to 500 mm (!162, !169)	○	○
165	Swing away device for the outrigger table (#072,!169)	○	○
166	3.200 mm crosscut fence, tiltable 90°-45°, 2 crosscut stops	S	S
167	Crosscut fence 3.200 mm with fine adjustment, tiltable 90°-45° , 1 digital crosscut stop up to 1.900 mm, telescopic fence with analogue crosscut stop up to 3.200 mm.	○	○
168	3.200 mm crosscut fence with fine adjustment, tiltable 90°-45°, 2 digital crosscut stops	○	○
175	Crosscut fence with two digital stops, incl. calculation of the length compensation when the fence is tilted (#161/162) Digi compensation plus	○	○

Machine control system			
61	Thermal label printer for interactive label printing (#23 K550X+E K590X+E)	○	○

Important accessories			
220	604-110 – Parts list holder with A4 clipboard	○	○
23	Bracket for the label printer	○	○

Packaging			
221	Container transport preparation	○	○

**Product range**



Sliding Table Panel Saws



Spindle Moulders

Planer



Edgebanders



Wide Belt Sanding & Brushing Machines

Heated Veneer Presses



CNC Machining Centres



Nesting-CNC Machining Centres



Industrial Panel Saws



Vacuum panel lifter, Return systems & Feeding Units

# **FORMAT 4**®

## **FORMAT4 Uncompromising expertise for the highest of requirements**

The Felder Group premium brand has met the highest standards of professional users since 2001.

The customised high-performance solutions are uncompromisingly innovative, offer maximum operating comfort and complete productivity.

### **FELDER GROUP**

KR-Felder-Straße 1  
A-6060 HALL in Tirol

🇬🇧 Tel. 01908 635000

[www.format-4.uk](http://www.format-4.uk)

[Contact](#)

🇮🇪 Tel. 0906625756

[www.format-4.ie](http://www.format-4.ie)

[Contact](#)

🇮🇳 Tel. 1800 274 3040

[www.format-4.in](http://www.format-4.in)

[Contact](#)

🌐 Tel. +43 5223 58500

[www.format-4.int](http://www.format-4.int)

[Contact](#)