

Download your local language



CZ DA DE EN ES LV
FR HU IT NL PL PT
RO RU SV FI SE

<http://fg.am/ba-manuals>



Hammer®

Operating Manual

GER = Original operating manual language
Other languages = Translation of the original operating manual

Bandsaw N2-35



Keep this manual handy and in good condition for continual reference!

 **Attention!** The machine must be inspected immediately upon arrival. If the machine has been damaged during transport, or if any parts are missing, a written record of the problems must be submitted to the forwarding agent and a damage report compiled. Also be sure to notify your supplier immediately.

 For the safety of all personnel, it is necessary to study this manual thoroughly before assembly and operation. This manual must be kept in good condition and should be considered as part of the machine. Furthermore, the manual must be kept to hand and within the vicinity of the machine so that it is accessible to operators when using, maintaining or repairing the machine.

HAMMER | A product of the FELDER GROUP!

FELDER KG

KR-Felder-Straße 1, 6060 Hall in Tirol, AUSTRIA

 +43 (0) 5223 / 58 50 0

 +43 (0) 5223 / 56 13 0

info@felder-group.com
www.felder-group.com

Content

1 General.....	6
1.1 Symbol legend	6
1.2 Information about the manual	6
1.3 Copyright	6
1.4 Liability and warranty	7
1.5 Warranty notice	7
1.6 Spare parts.....	7
1.7 Disposal.....	7
2 Safety	8
2.1 Intended use	8
2.2 Manual contents.....	8
2.3 Making changes and modifications to the machine.....	9
2.4 Responsibilities of the operator	9
2.5 Personnel requirements	9
2.6 Work safety.....	9
2.7 Personal protective equipment	10
2.8 Machine hazards	10
2.9 Other risks.....	11
2.10 Foreseeable misuse.....	11
3 Declaration of Conformity	12
4 Specifications	14
4.1 Dimensions and weight	14
4.2 Operation and storage conditions	15
4.3 Electrical connection	15
4.4 Dust Extractors	15
4.5 Noise emission	16
5 Setting up the machine	18
5.1 Overview	18
5.2 Data plate	19
5.3 Safety break switches.....	19
5.4 Automatic braking system	19
6 Transport, packaging and storage	20
6.1 Safety instructions.....	20
6.2 Transport inspection	20
6.3 Packaging	20
6.4 Storage	21
6.5 Transport.....	21
6.5.1 Transport locking device.....	21
6.5.2 Transport with a crane	22
6.5.3 Transport with a rolling carriage	22

Content

7 Setup and installation	24
7.1 Safety instructions.....	24
7.2 Setup.....	24
7.2.1 Assemble machine frame (Option).....	25
7.2.2 Attaching the band saw to the machine frame	26
7.2.3 Setting up the work table / Angle adjustment	27
7.2.4 Assembly - Rip fence.....	28
7.2.5 Positioning and levelling the machine.....	29
7.3 Electrical connection	30
8 Operation	32
8.1 Safety instructions.....	32
8.2 Blade selection and maintenance	33
8.3 Saw blade replacement/tension	34
8.3.1 Setting - Saw blade track / Lower wheel	35
8.4 Tilting the table	36
8.5 Adjusting the saw blade guide	36
8.5.1 Height adjustable protection device	36
8.5.2 Saw blade guide - upper	37
8.5.3 Saw blade guide - down (Option).....	38
8.6 Switching on the machine / Switching off the machine.....	39
8.7 Authorised working techniques	39
8.7.1 Longitudinal cut along the marked line.....	39
8.7.2 Cutting round workpieces in the transverse direction	40
8.7.3 Cutting workpieces on the upright edge	40
8.7.4 Longitudinal cut of narrow or thin workpieces with the longitudinal guide fence	40
8.7.5 Mitre cuts	41
8.7.6 Circular cuts	41
8.7.7 Diagonal cross-cut of rectangular workpieces.....	41
9 Service	42
9.1 Safety instructions.....	42
9.2 Tightening/replacing the drive belt	42
9.3 Upper wheel - Replace	43
9.4 Cleaning and lubrication	44
9.4.1 Adjustment - saw belt tension	44
9.4.2 Gearbox - Height adjustable protection device.....	44
9.4.3 Tilttable table	45
9.5 Direction of cut and parallelism	45
10 Faults	46
10.1 Safety instructions.....	46
10.2 What to do if a fault develops.....	46
10.3 What to do after rectifying the fault	46
10.4 Faults, causes and repairs.....	47

General

1 General

1.1 Symbol legend

Important technical safety instructions in this manual are marked with symbols. These instructions for work safety must be followed.

In all these particular cases, special attention must be paid in order to avoid accidents, injury to persons or material damage.



Warning! Risk of injury or death!

This symbol marks instructions that must be followed in order to avoid harm to one's health, injuries, permanent impairment or death!



Warning! Danger! Electric current!

This symbol warns of potentially dangerous situations relating to electric current. Not observing the safety instructions increases the risk of serious injury or death. All electrical repairs must be carried out by a qualified electrician!



Attention! Risk of material damage!

This symbol marks instructions which, if not observed, may lead to material damage, functional failures and/or machine breakdown!



Note:

This symbol marks tips and information which should be observed to ensure efficient and failure-free operation of the machine.

1.2 Information about the manual

This manual describes how to operate the machine properly and safely. Be sure to follow the safety tips and instructions stated here as well as any local accident prevention regulations and general safety regulations. Before beginning any work on the machine, ensure that the manual, in particular the chapter entitled "Safety" and the respective safety guidelines, has been read in its

entirety and fully understood. This manual is an integral part of the machine and must therefore be kept in the direct vicinity of the machine and be accessible at all times. If the machine is sold, rented, lent or otherwise transferred to another party, the manual must accompany the machine.

1.3 Copyright

This manual should be handled confidentially. It is designated solely for those persons who work on or with the machine. All descriptions, texts, drawings, photos and other depictions are protected by copyright and other commercial laws. Illegal use of the materials is punishable by law.

This manual, in its entirety or parts thereof, may not be transferred to third parties or copied in any way or form, and its contents may not be used or otherwise communicated without the express written consent of the manufacturer.

Infringement of these rights may lead to a demand for compensation or other applicable claims. We reserve all rights in exercising commercial protection laws.

General

1.4 Liability and warranty

The contents and instructions in this manual have been compiled in consideration of current regulations and state-of-the-art technology as well as based on our know-how and experience acquired over many years. This manual must be read carefully before commencing any work on or with this machine. The manufacturer shall not be liable for damage and/or faults resulting from the disregard of instructions in the manual. The text and images do not necessarily represent the delivery contents. The images and graphics are not depicted on a 1:1

scale. The actual delivery contents are dependent on custom-build specifications, add-on options or recent technical modifications and may therefore deviate from the descriptions, instructions and images contained in the manual. Should any questions arise, please contact the manufacturer. We reserve the right to make technical modifications to the product in order to further improve user-friendliness and develop its functionality.

1.5 Warranty notice

The guarantee period is in accordance with national guidelines. Details may be found on our website, www.felder-group.com

1.6 Spare parts



Attention! Risk of material damage!

Non genuine, counterfeit or faulty spare parts may result in damage, cause malfunction or complete breakdown of the machine.

If unauthorised spare parts are fitted into the machine, all warranty, service, compensation and liability claims against the manufacturer and their contractors, dealers and representatives shall be rejected.

Use only genuine spare parts supplied by the manufacturer.



Note: The original spare parts that have been authorised for use are listed in a separate spare parts catalogue, enclosed in the documentation package supplied with the machine.

1.7 Disposal



Attention! Used electrical materials, electronic components, lubricants and other auxiliary substances must be treated as hazardous waste and may only be disposed of by specialised, licensed firms.

If the machine is to be disposed of, separate the components into the various materials groups in order to allow them to be reused or selectively disposed of. The whole structure is made of steel and can therefore be dismantled without problem. This material is also easy to dispose of and does not pol-

lute the environment or jeopardise public health. International environmental regulations and local disposal laws must always be complied with.

Safety

2 Safety

At the time of its development and production, the machine was built in accordance with prevailing technological regulations and therefore conforms to industry safety standards.

However, hazards may arise should the machine be operated by untrained personnel, used improperly or employed for purposes other than those it was designed for. The chapter entitled "Safety" offers an overview of all the important safety considerations necessary to optimise

safety and ensure the safe and trouble-free operation of the machine.

To further minimise risks, the other chapters of this manual contain specific safety instructions, all marked with symbols. Besides the various instructions, there are a number of pictograms, signs and labels affixed to the machine that must also be heeded. These must be kept visible and must not be removed.

2.1 Intended use



Attention! Risk of material damage!

Machining materials other than wood is only permitted with the express written consent of the manufacturer. Operational safety is guaranteed only when the machine is used for the intended purposes.

The machine described in this manual is intended solely for processing wood and similar machinable materials.

This includes all wood based panel material (e.g. Chip-board, OSB panels, MDF, Plywood etc.), even if they are laminated or edged with plastic or a light metal. Other materials are cardboard, cork, bone and all rigid plastics (thermoset plastics and thermo plastics) as long as whilst machining them it does not lead to any risks from dust, chips or thermal degradation products.

This information can be taken from the relevant safety sheets

The term "proper use" also refers to correctly observing the operating conditions as well as the specifications and instructions in this manual.

The machine may only be operated with parts and original accessories from the manufacturer.



Attention! Any use outside of the machine's intended purpose shall be considered improper and is therefore not permitted. All claims regarding damage resulting from improper use that are made against the manufacturer and its authorised representatives shall be rejected. The operator shall be solely liable for any damage that results from improper use of the machine.

2.2 Manual contents

All those appointed to work on or with the machine must have fully read and understood the manual before commencing any work. This requirement must be met even if the appointed person is familiar with the operation of such a machine or a similar one, or has been trained by the manufacturer.

Knowledge about the contents of this manual is a pre-

quisite for protecting personnel from hazards and avoiding mistakes so that the machine may be operated in a safe and trouble-free manner. It is recommended that the operator requests proof from the personnel that the contents of the manual have been read and understood.

Safety

2.3 Making changes and modifications to the machine

In order to minimise risks and to ensure optimal performance, it is strictly prohibited to alter, retrofit or modify the machine in any way without the express consent of the manufacturer.

All the pictograms, signs and labels affixed to the

machine must be kept visible, readable and may not be removed. Pictograms, signs and labels that have become damaged or unreadable must be replaced promptly.

2.4 Responsibilities of the operator

This manual must be kept in the immediate vicinity of the machine and be accessible at all times to all persons working on or with the machine. The machine may only be operated if it is in proper working order and in safe condition. The general condition of the machine must be controlled and the machine must be inspected for visible defects every time before it is switched on. All instructions in this manual must be strictly followed without reservation.

Besides the safety advice and instructions stated in this manual, it is necessary to consider and observe local

accident prevention regulations, general safety regulations as well as current environmental stipulations that apply to the operational range of the machine. The operator and designated personnel are responsible for the trouble-free operation of the machine as well as for clearly establishing who is in charge of installing, servicing, maintaining and cleaning the machine. Machines, tools and accessories must be kept out of the reach of children.

2.5 Personnel requirements

Only authorised and trained personnel may work on and with the machine. Personnel must be briefed about all functions and potential dangers of the machine. "Specialist staff" is a term that refers to those who – due to their professional training, know-how, experience, and knowledge of relevant regulations – are in a position to assess delegated tasks and recognise potential risks. If the personnel lack the necessary knowledge for working on or with the machine, they must first be trained. Responsibility for working with the machine (installation, service, maintenance, overhaul) must be clearly defined and strictly observed. Only those persons who can be expected to carry out their work reliably may be given permission to work on or with the machine. Personnel

must refrain from working in ways that could harm others, the environment or the machine itself. It is absolutely forbidden for anyone who is under the influence of drugs, alcohol or reaction-impairing medication to work on or with the machine. When appointing personnel to work on the machine, it is necessary to observe all local regulations regarding age and professional status. The user is also responsible for ensuring that unauthorised persons remain at a safe distance from the machine. Personnel are obliged to immediately report any irregularities with the machine that might compromise safety to the operator.

2.6 Work safety

Following the safety advice and instructions given in this manual can prevent bodily injury and material damage while working on and with the machine. Failure to observe these instructions can lead to bodily injury and damage to or destruction of the machine. Disregard of the safety advice and instructions given in this manual

as well as the accident prevention regulations and general safety regulations applicable to the operative range of the machine shall release the manufacturer and their authorised representatives from any liability and from all compensation claims.

Safety

2.7 Personal protective equipment

When working on or with the machine, the following must be strictly observed:



Persons with long hair who are not wearing a hairnet are not permitted to work on or with the machine!



It is prohibited to wear gloves while working on or with the machine.

When working on or with the machine, the following must always be worn by personnel:



Protective clothes

Sturdy, tight-fitting clothing (tear-resistant, no wide sleeves, no jewellery (rings, bracelets, necklaces, etc.)).



Protective footwear

To protect the feet from heavy falling objects and prevent sliding on slippery floors



Hearing protection

To protect against loss of hearing



Safety glasses

Wear safety goggles

2.8 Machine hazards



Note: Ignition sparks may be generated during machining.

Carefully inspect workpieces for foreign matter (nails, screws) which might impair processing.

The machine has undergone a hazard analysis. The design and construction of the machine are based on the results of this analysis and correspond to state-of-the-art technology.

The machine is considered operationally safe when used

properly.

Nevertheless, there are some remaining risks that must be considered.

The machine runs at high electrical voltage.



Warning! Danger! Electric current!

Electrical energy can cause serious bodily injury. Damaged insulation materials or defective individual components can cause a life-threatening electrical shock.

- Before carrying out any maintenance, cleaning and repair work, switch off the machine and ensure that it can not be accidentally switched on again.
- When carrying out any work on the electrical equipment, ensure that the voltage supply is completely isolated.
- Do not remove any safety devices or alter them to prevent them from functioning correctly.

Safety

2.9 Other risks



Warning! Risk of injury!

Even if the safety measures are complied with, there are still certain associated risks that must be considered when working on the machine:

General safety rules:

- Be wary of sharp edges to avoid cutting yourself, in particular when changing the tooling.
- Risk of injury due to ejected work pieces and parts of work pieces (e.g. branches, chips).
- Risk of injury from workpiece kickback.
- Hearing damage as a result of high noise levels.
- Risk of damage to health from dust especially when working hard woods.
- Risk of injury through being crushed, cut, caught, wound up or sliced.

2.10 Foreseeable misuse



Note:

The examples mentioned here should be used to bring the attention to the hazards that can occur, but are not a complete list and should not be used as a legal basis.

Nevertheless, this information is provided to help the operator better assess hazards and risks.

General safety rules:

- Failure to follow the operation manual.
- Operating the machine, even if the operation manual is incomplete or not in the language of the country it is in.
- Placing of material or tools on the work surface.
Components and tools that are not put in their correct place or put away may be the cause of accidents!
- Usage of a tool system that is not suited for the material or the machine.
Only clamp authorised tools to the machine.
- Usage of a modified module and tool system.
Only use original manufacturer tools
- Fitting of spare parts and usage of tools and accessories that are not permitted by the manufacturer.
Use only genuine spare parts supplied by the manufacturer.
- Making changes and modifications to the machine.
- Bridging or adaptation of protective equipment.

During operation:

- Processing of workpieces that are too large or too heavy.
- Processing of very small workpieces without assistance.
Keep handling auxiliaries at hand: See chapter entitled >Operation<
- Processing of unsuitable materials such as metal.
- Processing of workpieces that are not, or insufficiently held in place.
- Processing of workpieces in the same direction as the rotation of the tool.
(Feed direction corresponds to the rotational direction of the tool.)
- Using the machine without the appropriate safety equipment.
Ensure that all safety devices have been installed properly.
- Deliberately bad or irresponsible behaviour on the machine whilst operating.

Every time the machine is being serviced:

- Service work carried out by untrained or unauthorised personnel.
- Non-compliance with maintenance guidelines.
See chapter entitled >Service - Maintenance schedule<
- Failure to observe signs of wear and damage.

Declaration of Conformity

3 Declaration of Conformity



EG-Declaration of Conformity
According to Machine Guidelines 2006/42/EG

We hereby declare that the machine indicated below, which corresponds to the design and construction of the model we placed on the market, conforms with the health and safety requirements as stated by the EC guidelines (see table).

Manufacturer:	Felder KG KR-Felder-Straße 1, 6060 Hall in Tirol, AUSTRIA
Product designation:	Bandsaw
Make:	HAMMER
Model designation:	N2-35
The following EC guidelines were applied:	2006/42/EC
The following harmonised norms were applied:	EN ISO 19085-1:2021 EN ISO 19085-16:2021

This EC Declaration of Conformity is valid only if the CE label has been affixed to the machine.

Modifying or altering the machine without the express written agreement of the manufacturer shall render the warranty null and void.

The signatory of this statement is the appointed agent for the compilation of the technical information

Hall in Tirol, 21.01.2026

Prof. h.c. Ing. Johann Georg Felder
CEO FELDER KG
KR-Felder-Straße 1, 6060 Hall in Tirol, AUSTRIA

Declaration of Conformity



Declaration of Conformity
According to UK Directive S.I. 2008/1597

We hereby declare that the machine indicated below, which corresponds to the design and construction of the model we placed on the market, conforms with the health and safety requirements as stated by the UK guidelines (see table).

Manufacturer:	Felder KG KR-Felder-Straße 1, 6060 Hall in Tirol, AUSTRIA
Product designation:	Bandsaw
Make:	HAMMER
Model designation:	N2-35
The following UK guidelines were applied:	S.I. 2008/1597 S.I. 2016/1091
The following harmonised norms were applied:	EN 1807-1:2013 EN ISO 12100:2010 EN 60204-1:2018

This Declaration of Conformity is valid only if the UKCA label has been affixed to the machine.

Modifying or altering the machine without the express written agreement of the manufacturer shall render the warranty null and void.

The signatory of this statement is the appointed agent for the compilation of the technical information

Hall in Tirol, 21.01.2026

Prof. h.c. Ing. Johann Georg Felder
CEO FELDER KG
KR-Felder-Straße 1, 6060 Hall in Tirol, AUSTRIA

Specifications

4 Specifications

4.1 Dimensions and weight

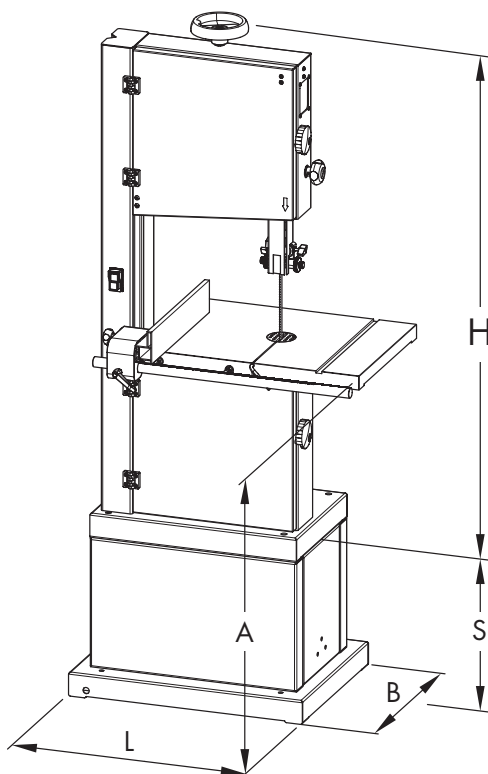

Fig. 4-1: Total size

Machine	N2-35
Total size	600 (L) x 460 (B) x 1310 (H) / 1700 mm (H+S) 935 mm (A)
Package size	1325 (L) x 455 (B) x 785 (H) mm
Net weight	100 kg

Bandsaw	N2-35
Cutting height	235 mm
Rip capacity max.	340 mm
- -Rip fence	295 mm
Saw blade length	2630 mm
Saw blade width	6-20 mm
Saw blade speed	15,5 m/sec
Wheel diameter	350 mm
Table size	400 x 548 mm
Tiltable table	-5° max. +45°

Specifications

4.2 Operation and storage conditions

Operating/room temperature	+10 to +40 °C
Storage temperature	-10 to +50 °C

4.3 Electrical connection

Machine	Alternating-current motor	Three-phase current motor
N2-35		
Motor voltage	1x 230 V	-
motor frequency	50/60 Hz	-
Motor power S1	1,1 kW	-

*) S6 = operation under load and intermittent service; 40% = relative operating factor

mains voltage according to specification plate	±10%
Safeguarding	12 A
Power supply cord (H07RN-F)	3x1,5 mm ²
Triggering characteristic	C

4.4 Dust Extractors

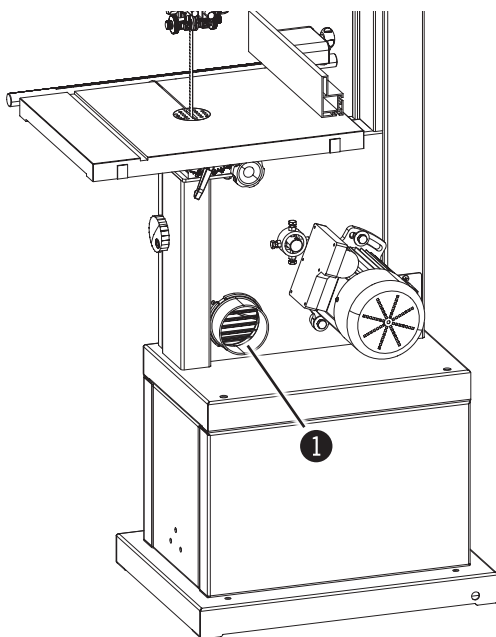

Fig. 4-2: Connection ports

① Connection ports 100 mm

The machine has to be connected to a dust extractor. The connection values and the position of the connection port are shown on the picture.

The air speed at the connection point has to be a minimum of 20 m/s for materials with a humidity less than 12 %.

The air speed should be increased to 25–28 m/s to extract dust from more humid materials (over 12 %).

Only flame resistant vacuum hoses can be used, conforming to DIN 4102 B1 and any other safety regulations in effect

Extraction connection-Ø	100 mm
Air speed	20 m/s
Min. depression	1138 Pa
Volume flow min.	565 m ³ /h

Specifications

4.5 Noise emission

The given values are emission values and not safe workplace values. Although there is a correlation between emission and immission levels, it is not possible to state whether increased safety measures are required.

Factors which can considerably influence the present immission level at the workplace include the duration of exposure, the character of the work area and other influences in the neighbouring area.

Acceptable workplace values may also vary from country to country. However, this information should help the user to better assess the hazards and risks.

Depending on the installation location and other variables, the resulting noise emission can differ by up to 4 db (A) from the given values.



Note:

To keep the noise emission as low as possible, always use sharpened tools and operate the machine at the correct speed.

Do not overload the machine! It is safer and performs better if operated within its power range.

Ear protection must always be worn; however, such protection cannot be considered a substitute for properly sharpened tools.

All values in dB(A) and with a measurement uncertainty factor of 4 dB(A).

Model	L Aeq	LW (A)	Lpc	
N2-35	73,3 dB (A)	84,1 dB (A)	2,3 mW	< 130 dB (A)

Specifications

Setting up the machine

5 Setting up the machine

5.1 Overview

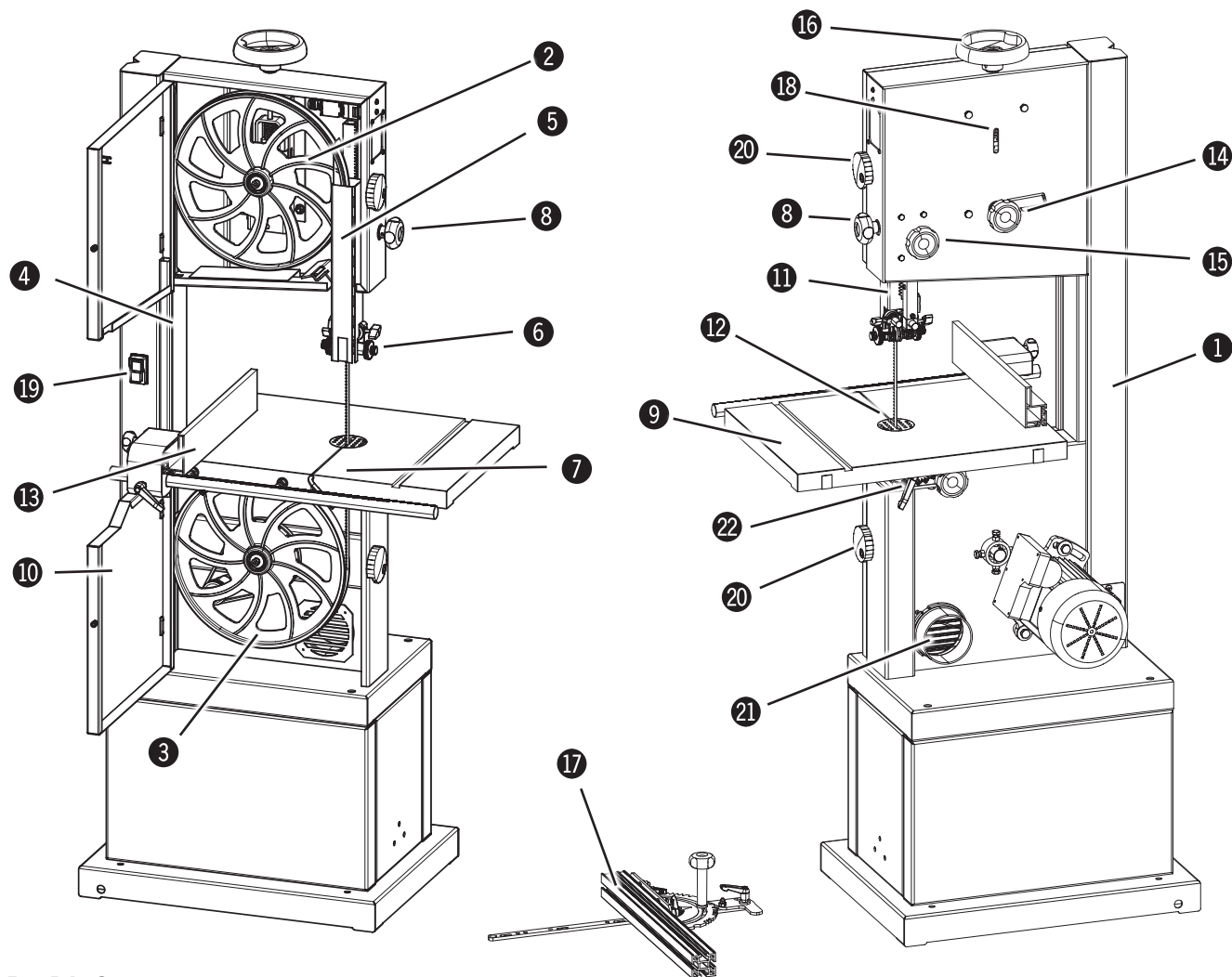
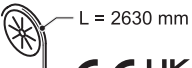



Fig. 5-1: Overview

- | | |
|---------------------------------------|---|
| ① Machine base-frame | ⑬ Guide fence
Saw blade track - Adjuster hand wheel and clamp |
| ② Upper wheel | ⑭ ping level |
| ③ Lower wheel | ⑮ Lock wheel - Blade guide height adjustment |
| ④ Rising part of saw blade | ⑯ Blade tension hand wheel |
| ⑤ Falling part of saw blade | ⑰ mitre fence (Accessories) |
| ⑥ Upper blade guide | ⑱ Saw blade tension indicator window |
| ⑦ Lower blade guide (Optional) | ⑲ On/Off switch |
| ⑧ Blade guide height adjustment | ⑳ Lock wheel - Wheel door |
| ⑨ Work bench | ㉑ Vacuum connector
Tilttable table (Adjuster hand wheel and clamping |
| ⑩ Wheel door | ㉒ lever) |
| ⑪ Height adjustable protection device | |
| ⑫ Table insert | |

Setting up the machine

5.2 Data plate

TYPE : N2-35		NR. :	
BANDSÄGEMASCHINE			
Baujahr / year of constr. / annee de constr. : 2021			
V: 230	PH: 1	 L = 2630 mm	
KW: 1.1	HZ: 60		
RPM: 3400	A: 7.3	15.5 m/s	
ISOL-CLASS: F / IP54			
 www.hammer-maschinen.at		KR-Felder-Straße 1 6060 HALL in Tirol AUSTRIA Tel. +43 5223 58500 Fax +43 5223 56130	

The data plate displays the following specifications:

- Manufacturer information
- Model designation
- Machine number
- Voltage
- Phases
- Frequency
- Motor power
- Power supply
- Year of construction
- Motor specifications

Fig. 5-2: Data plate

5.3 Safety break switches

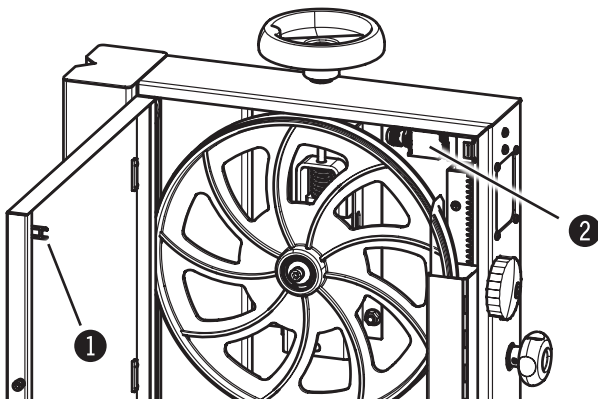

Fig. 5-3: Lock system

The machine only runs when the end switch in the inside of the machine frame is engaged by the locking device

- ① Lock system
- ② Break switch

5.4 Automatic braking system



Warning! Risk of injury!

In the event of a power supply failure, the electric brake is deactivated. The tool can therefore not come to a complete stop within 10 seconds.

In this case, the machine will stop without using the the automatic braking system!

Your machine is equipped with an automatic braking unit. All necessary adjustments are done ex factory.

Please contact the FELDER KG service department, if problems or a fault- function should occur!

Transport, packaging and storage

6 Transport, packaging and storage

6.1 Safety instructions



Attention! Risk of material damage!

The machine can be damaged or destroyed if it is subjected to improper handling during transport.



Warning! Risk of injury!

There is a risk of injury as a result of falling parts while transporting, loading or unloading the machine.

For this reason the following safety instructions must be observed:

- Never lift loads over a person.
- Always move the machine with the utmost care and caution.
- Only use suitable lifting accessories and hoisting devices that have a sufficient load-carrying capacity.
- Never lift the machine by its protruding parts (e.g. sliding table).
- Consider the machine's centre of gravity when transporting it (minimise the risk of it tipping over).
- Take measures to prevent the machine from slipping sideways.
- Ropes, belts or other hoisting devices must be equipped with safety hooks.
- Do not use torn or worn ropes.
- Do not use knotted ropes or belts.
- Ensure that ropes and belts do not lie against sharp edges.
- Transport the machine as carefully as possible in order to prevent damage.
- Avoid subjecting the machine to shocks.
When transporting the machine overseas, ensure that the packaging is airtight and that a desiccant is added to protect the metal parts against corrosion.

6.2 Transport inspection

Upon arrival, inspect the shipment to ensure that it is complete and has not suffered any damage. If any transport damage is visible, do not accept the delivery or only accept it with reservation. Record the scope of the damage on the transport documents/delivery note. Initiate the complaint process.

For all defects that are not discovered upon delivery, be sure to report them as soon as they are recognised as damage claims must be filed within a certain period, as granted by law.

6.3 Packaging

If no agreement has been made with the supplier to take back the packaging materials, help to protect the environment by reusing the materials or separating them according to type and size for recycling.



Attention! Dispose of the packaging materials in an environmentally friendly way and always in accordance with local waste disposal regulations. If applicable, contract a recycling firm to dispose of the packaging materials.



Note: Help preserve the environment!

Packaging materials are valuable raw materials and in many cases they can be used again or expediently reprocessed or recycled.

Transport, packaging and storage

6.4 Storage

Keep items sealed in their packaging until they are assembled/installed and be sure to observe the stacking and storage symbols on the outside of the packaging.

Store packed items only under the following conditions

- Do not store outdoors.
- Store in a dry and dust-free environment.
- Do not expose to aggressive substances.
- Protect from direct sunlight.
- Avoid subjecting the machine to shocks.
- Storage temperature: -10° to $+50^{\circ}$ C.
- Maximum humidity: 60 %.
- Avoid extreme temperature fluctuations (condensation build-up).
- Apply a coat of oil to all bare machine parts (corrosion protection).
- When storing for longer than 3 months, apply a coat of oil to all bare machine parts (corrosion protection). Regularly check the general condition of all parts and the packaging. If necessary, refresh or re-apply the coat of anti-corrosive agent.
- If the machine is to be stored in a damp environment, it must be sealed in air-tight packaging and protected against corrosion (desiccant).

6.5 Transport



Attention! Risk of material damage!

Transport the machine according to the enclosed transport and assembly instructions!

The machine must not be lifted by the work table, sliding table or base! Ropes, belts and chains may only be fastened to the base of the machine.



Note:

The transportation width is well under 1000 mm. This makes it possible to transport the machine through doorways.

6.5.1 Transport locking device

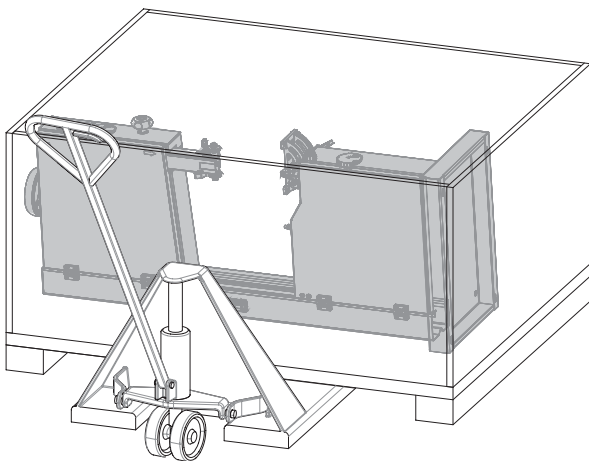

The machine is partly assembled when delivered on the pallet

The machine can be transported with a crane, forklift, pallet jack or rolling carriage.

Fig. 6-1: Transport locking device

Transport, packaging and storage

6.5.2 Transport with a crane

- !** Attention! Risk of material damage!: Do not lift the machine by its work table, extension frames or hand-wheels.
Align the straps correctly and check that the machine is properly supported. The machine must be raised slowly and very carefully to prevent the load from slipping.

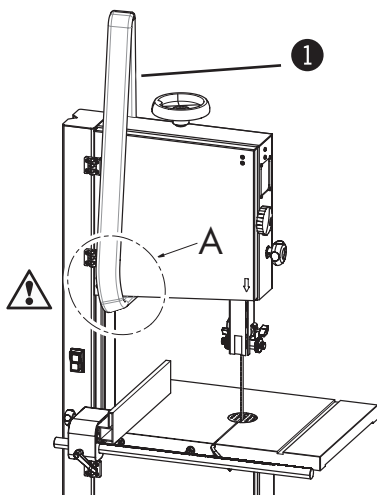

For crane transport only belts may be used.

Hang the straps in position A.

1 Belts

Fig. 6-2: Transport with a crane

6.5.3 Transport with a rolling carriage

- i** Note:
The rolling carriage and the lifting bar (option) facilitate the task of transporting the machine.

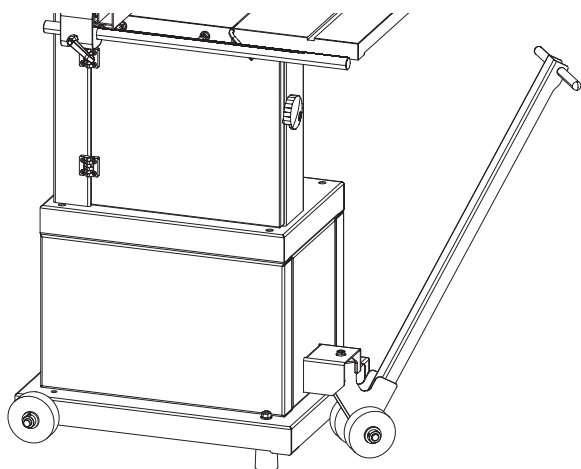

Accessories Order no.:
Rolling carriage - 503-142
Lifting bar - 500-149

Fig. 6-3: Transport with a rolling carriage

Transport, packaging and storage

Setup and installation

7 Setup and installation

7.1 Safety instructions



Warning! Risk of injury!: Improper assembly and installation can lead to serious physical injury or equipment damage. For this reason, this work may only be carried out by authorised, trained personnel who are familiar with how to operate the machine and in strict observance of all safety instructions.

- Ensure that there is sufficient space to work around the machine. Ensure there is ample distance between the machine and other solid constructions such as walls or other machines.
- Keep the work area orderly and clean. Components and tools that are not put in their correct place or put away may be the cause of accidents!
- Install the safety equipment according to the instructions and check that it functions properly.



Warning! Danger! Electric current!: Work on electrical fittings may only be carried out by qualified personnel and in strict observance of the safety instructions.

Before assembling and installing the machine, check to make sure it is complete and in good condition.



Warning! Risk of injury!: An incomplete, faulty or damaged machine can lead to serious physical injury or equipment damage. Only assemble and install the machine if the machine and its parts are complete and intact.



Attention! Risk of material damage!: Only operate the machine in ambient temperatures from +10°C to +40°C. If the instructions are not followed, damage may occur to bearings.

7.2 Setup

Installation site requirements:

- Operating/room temperature: +10° to +40°C.
- Ensure that the work surface is sufficiently stable and has the proper load-bearing capacity.
- Provide sufficient light at the workstation.
- Ensure there is sufficient clearance for or from neighbouring workstations.
- Risk of injury! Keep machines, tools and accessories etc. out of the reach of children.
- Vacuum hoses and electrical wires should be layed in such a way as to avoid tripping over them.

Setup and installation

7.2.1 Assemble machine frame (Option)



Warning! Heavy dead weights can easily cause an injury
To facilitate assembly, ensure the presence of a minimum of one additional people.



Note:
During the assembly of the machine frame, first loosely connect all parts.
Finally, tighten all screws.
Ensure the correct position of the drill holes when mounting the base walls!

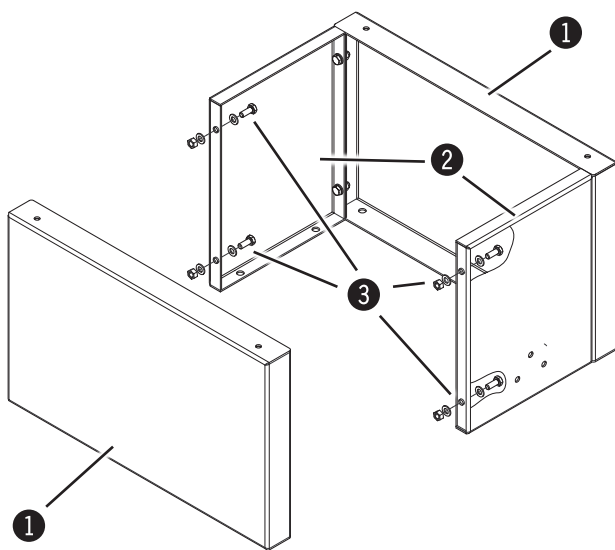

Fig. 7-1: Assembly - Machine frame

Due to technical reasons, the machine is delivered in a partly dismantled state.

- ① 2 x base wall - long
- ② 2 x base wall - short
- ③ 18 x Screws, Nuts, Shims
- ④ 1 x Base

Assembly - Machine frame:

1. Connect the base walls long and short with screws, nuts and washers.
2. Tighten the screws once the angularity is set.
3. Fasten the base plate to the mounted base walls.

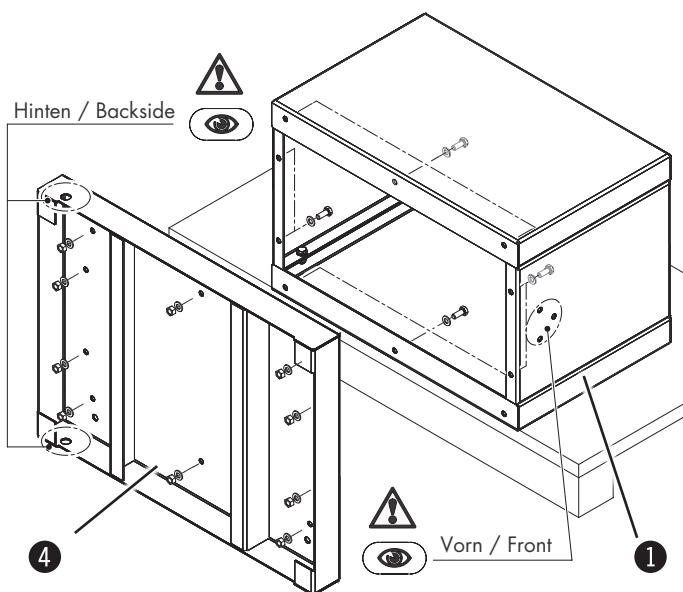

Fig. 7-2: Assembly - Machine frame

Setup and installation

7.2.2 Attaching the band saw to the machine frame



Warning! Heavy dead weights can easily cause an injury
To facilitate assembly, ensure the presence of a minimum of one additional people.



Note:
If the machine stand is not mounted on the machine frame, the machine must be placed on a stable and level surface at least 390 mm high.

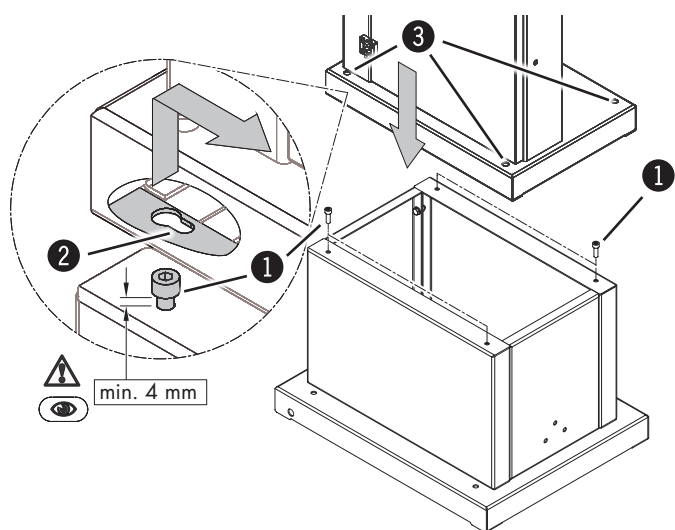

Assembly - Bandsaw:

1. Do not screw in the fastening screws completely. The distance between the bottom edge of the screw head and the machine base should be at least 4 mm.
2. Tighten the screws once the angularity is set. Move the machine in the direction of the slots.
3. Screw in the socket head cap screw with the hex key (can be reached via the bore).

- ① 4 x Fixing screws
- ② Slot
- ③ Bore

Fig. 7-3: Assembly - Bandsaw

Setup and installation

7.2.3 Setting up the work table / Angle adjustment

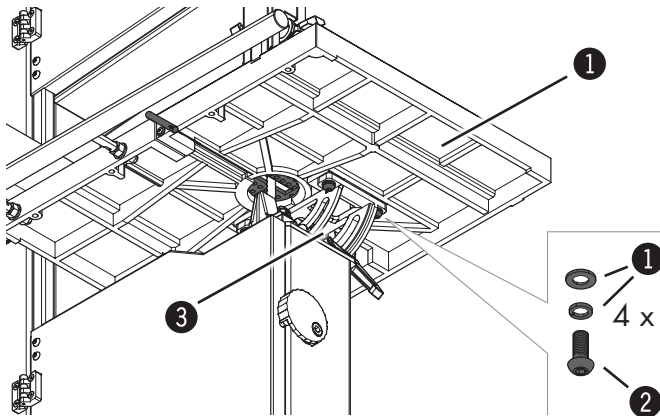

Fig. 7-4: Work table

Fasten the worktable to the clamp with screws and washers.

- ① Washers
- ② Screw
- ③ clamp
- ④ Work bench

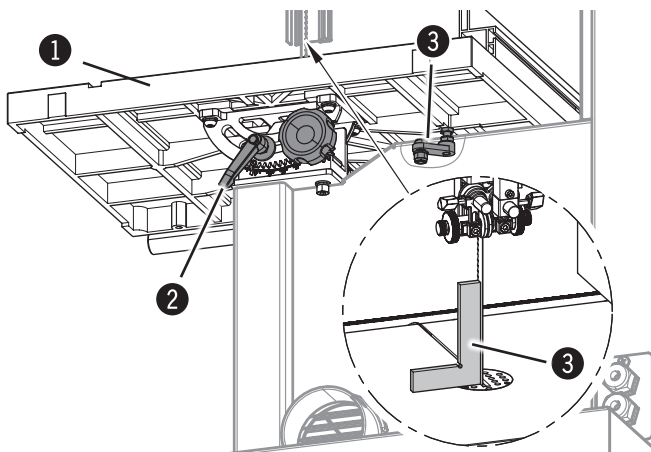

Fig. 7-5: 90° to saw band run

Disconnect the machine from the mains supply.
Levelling the machine / See chapter entitled 7.2.5
Tension saw blade / See chapter entitled 8.3

Angle adjustment: 90° to saw band run

Loosen the clamping lever.
Tilt the work table until it rests on the stop screw.
Place a 90° angle between the running surface of the saw band and the working table.
If the 90° in the initial position is not correct, adjust the stop screw accordingly.
Check the 90° angle once the clamping lever is back in place.

- ① Work table
- ② Clamping lever
- ③ Fence screw
- ④ 90° - Angle

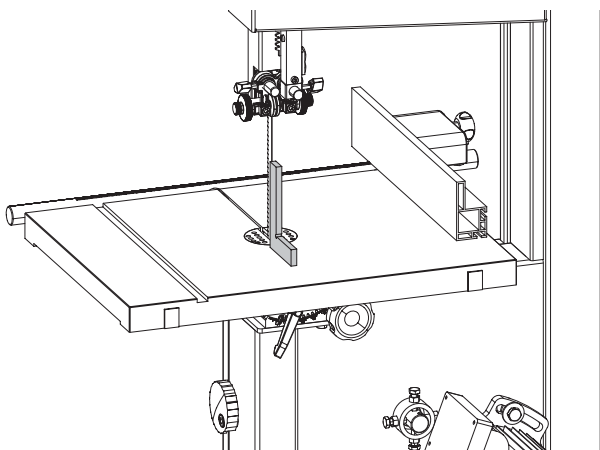

Fig. 7-6: 90° to the saw band back

Setup and installation

7.2.4 Assembly - Rip fence

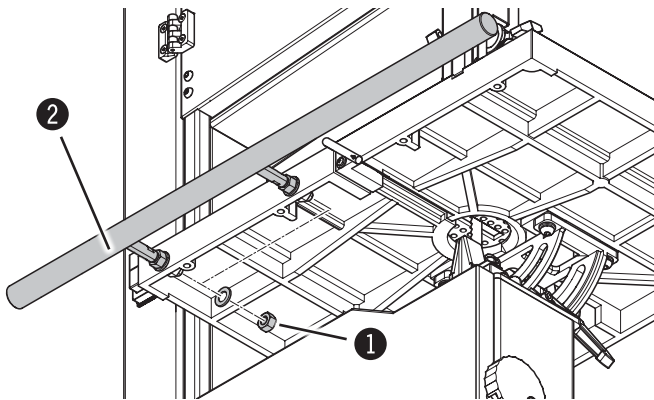

Fig. 7-7: Rip fence

Use a nut to mount the fence rail to the machine table.
Slide the premounted fence onto the track.

- ① Nut
- ② Fence rail

Height adjustment - Fence rail:

Adjust the distance: 18 mm
(This setting has to be exact.)
Loosen the lock nuts.
Place a 90° angle at the front edge of the table.
Adjust the distance X1.
Turn the setting nut by hand.
Adjust the distance X2.
Tighten the lock nuts.
Check the setting and readjust if necessary.

- ① Locking nut
- ② 90°- Angle
- ③ Fence rail

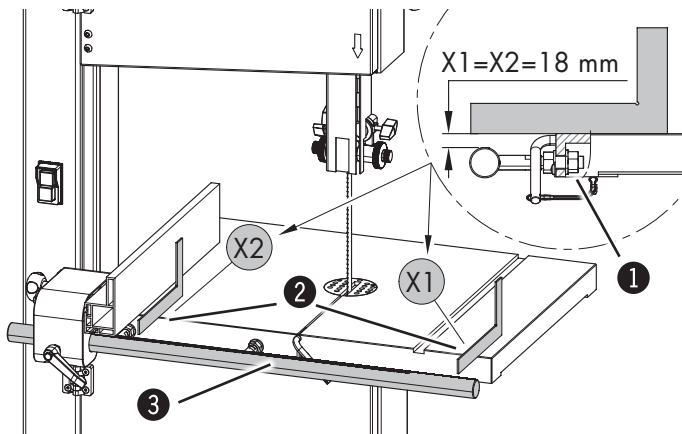

Fig. 7-8: Height adjustment - Fence rail

Setting the rip fence:

Move the rip fence to the left.
Measure the distance Y and X (Distance between stop ruler and table groove).
The values X and Y must be equal.
Loosen the right nut.
The angle can be adjusted by twisting the adjusting screw.
Y > X :turn - Anti-clockwise
Y < X :turn - Clockwise
Counter the right nut again.
Check the setting and readjust if necessary.

- ① Rip fence
- ② Nut - Right
- ③ Adjusting screw

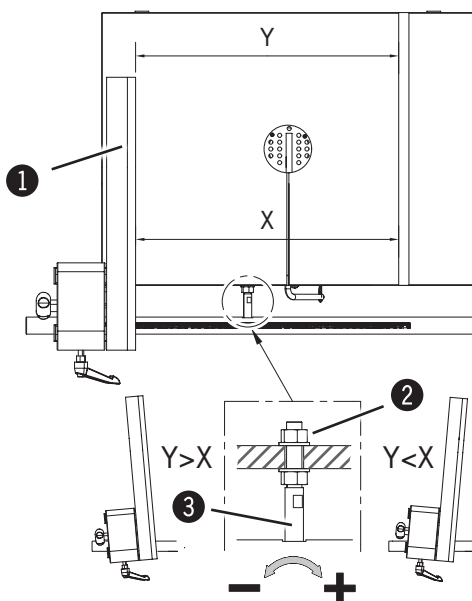

Fig. 7-9: Setting the rip fence

Setup and installation

7.2.5 Positioning and levelling the machine

- i** **Note:**
There are 4 threaded holes located in the base plate of the machine where the levelling screws supplied with the machine can be screwed into. (optional)

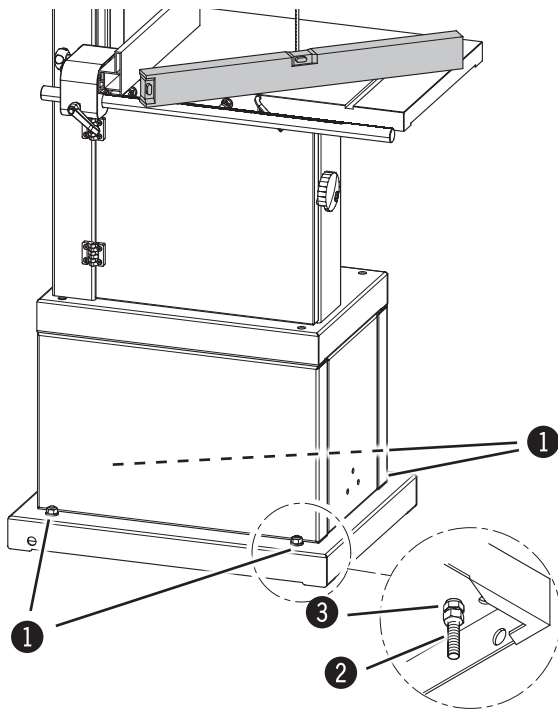

Fig. 7-10: Floor mounting

- ① Screws
- ② Adjusting screw
- ③ Locking nut

The following points are important for a correct and efficient machine installation:

- Position the machine with the aid of a spirit level to ensure that the machine functions precisely and operates smoothly.
- Compensate for uneven floors with the „adjusting screws“ or bolster the machine
- The machine should be bolted to the floor with M10 screws for optimum stability, however take care not to overtighten the fastening bolts as this will increase vibrations. It is advisable to place vibration dampening pads between the floor and the machine.
- Install the machine in such a way as not to amplify the vibrations and machine noise.
- Ensure that workplace lighting is adequate.
- If the machine is to be installed between other machines, leave at least 80 cm distance in-between, in order to avoid collisions when cutting large workpieces and to allow the use of equipment such as roll supports and additional tables.

Setup and installation

7.3 Electrical connection



Warning! Danger! Electric current!

Work on electrical fittings may only be carried out by qualified personnel and in strict observance of the safety instructions.

Checking the loop impedance and the suitability of the overcurrent protective device must take place at the location where the machine is to be commissioned!



Attention! Risk of material damage!

Before hooking up the machine to the power supply, compare the specifications on the data plate with those of the electrical network. Only hook up the machine if the two sets of data correspond to each other. The electrical outlet must have the appropriate socket (for a three-phase alternating current motor, CEE).



Note: Do not open the machine's switch box unless you have the express consent of the Hammer service department. Violating this stipulation shall render the right to make claims under the warranty null and void.



Attention! Risk of material damage!

The machine must be secured with an automatic fuse.

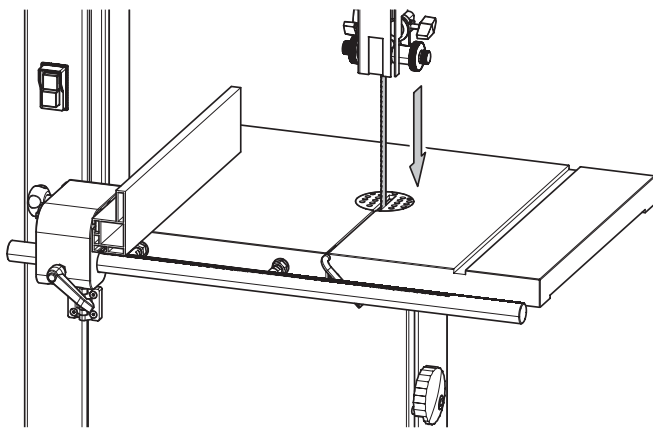

Fig. 7-11: Direction of the Motor rotation

1. Connect the plug to the power supply.
2. Switch on and let the machine run briefly.
3. While the motor is running, check its direction of rotation.
4. Should a change in the direction of rotation be necessary, switch the two phases on the power cable.

Electrical connection requirements

- The machine must be earthed with electrical conductors.
- The voltage fluctuations in the mains supply may not exceed $\pm 10\%$.
- The switch cabinet must be fitted with a circuit breaker (DIN VDE 0641).
- Power supply cable H07RN-F at least 5x 2,5 (rotary-current motor) or 3x 2,5 (alternating-current motor).
- Safeguarding/Power supply cord: see "Technical data"
- The power supply cable must be protected against damage (e.g. armoured conduit).
- The power supply cable must be laid in such a way so it does not overbend or chafe and there is no risk of tripping over it.

Setup and installation

Operation

8 Operation

8.1 Safety instructions



Warning! Risk of injury! Improper operation may lead to severe physical injury or material damage. For this reason, this work may only be carried out by authorised, trained personnel who are familiar with how to operate the machine and in strict observance of all safety instructions.

Before starting work:

- Before assembling and installing the machine, check to make sure it is complete and in good condition.
- Ensure that there is sufficient space to work around the machine.
- Keep the work area orderly and clean. Components and tools that are not put in their correct place or put away may be the cause of accidents!
- Ensure that all safety devices have been installed properly.
- Adjustments to the machine or tool replacement may only be conducted once the machine has stopped.
- Only clamp authorised tools to the machine.
- Install the dust extraction system according to the instructions and test its function.
- Only machine workpieces that can be safely placed on the machine and guided.
- Carefully inspect workpieces for foreign matter (nails, screws) which might impair processing.
- Support long workpieces with additional surface equipment (e.g. Table extensions, roll supports).
- Ensure that each unit is rotating in the proper direction.
- Keep tools for handling short and narrow workpieces close at hand.
- Before switching on the machine, always check to make sure that there are no other persons in the immediate vicinity of the machine.

During operation:

- When changing to another workpiece or if a malfunction occurs, first switch off the machine and then secure it against being switched on again accidentally.
- Do not switch off, circumvent or decommission protective and safety devices during operation.
- Do not overload the machine! It is safer and performs better if operated within its power range.

When working on or with the machine, the following must be strictly observed:

- Persons with long hair who are not wearing a hairnet are not permitted to work on or with the machine!
- It is prohibited to wear gloves while working on or with the machine.

When working on or with the machine, the following must always be worn by personnel:

- Sturdy, tight-fitting clothing (tear-resistant, no wide sleeves, no jewellery (rings, bracelets, necklaces, etc.)).
- Protective footwear To protect the feet from heavy falling objects and prevent sliding on slippery floors.
- Hearing protection To protect against loss of hearing.



Attention! Risk of material damage!

Only operate the machine in ambient temperatures from +10°C to +40°C. If the instructions are not followed, damage may occur to bearings.

Improper use such as cutting too tight a radius or with too much cutting pressure could cause friction and lead to sparks being generated by the blade guides.

In order to prevent sparks being generated, it is recommended that Super Glide (article number 10.0.010) is used on a regular basis (sprayed on to the guides).

Operation

8.2 Blade selection and maintenance

- i** Selecting the type of saw blade and its width, depends on the material to be cut and the type of cut:
- Narrow saw blades are designed for curved and circular cuts, whereas wide saw blades are designed for straight cuts.
 - A fine-toothed saw blade is required for hard wood, whereas a coarse-toothed saw blade is required for soft wood.

The following saw blades may be used:

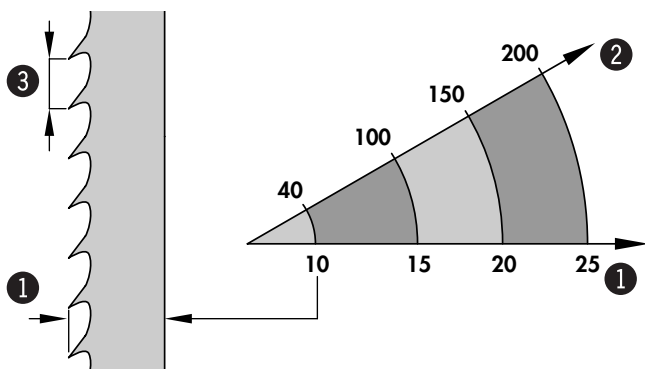

Fig. 8-1: Saw blades

N2-35 - Length: 2630 mm		
Art. No.	SB	ZT
13.7.3506	6 mm	4,0 mm
13.7.3510	10 mm	6,0 mm
13.7.3515	16 mm	6,0 mm
13.7.3520	20 mm	8,0 mm

- ① Blade width (SB)
- ② Radius cut
- ③ Tooth spacing (ZT)

The gap between the individual teeth should be large enough to carry the material chips and to throw them away. If the gap is too small, the blade will overheat and rupture.

Do not use kinked, ruptured or bent saw blades.

For soft wood, the set should be a max. of twice the thickness of the saw blade and for hard wood, a max. of 1.5 times the thickness of the saw blade.

Change blunt blades and have them sharpened by a specialist workshop or purchase a new saw blade.

It is recommended to use only high quality saw blades.

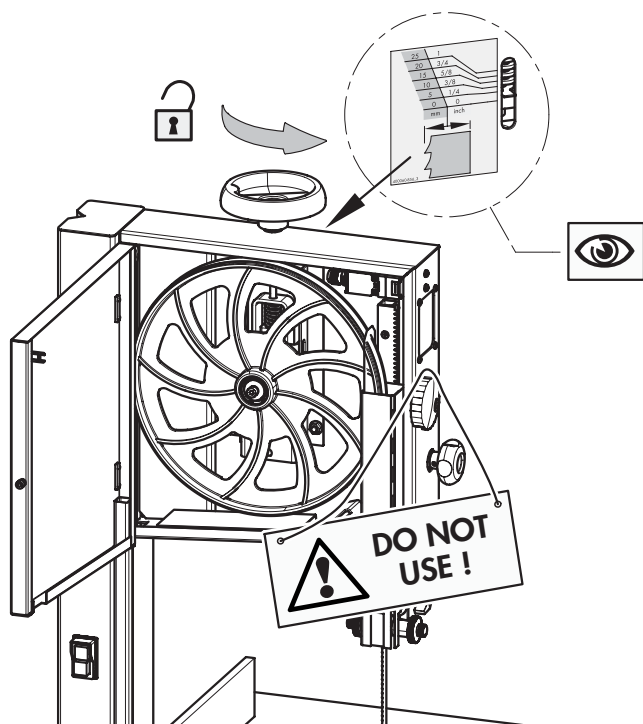

Fig. 8-2: Release saw band tension

- i** **Attention!** Once the machine is no longer in use, loosen the belt tension and place an appropriate warning sign on the machine. This will thus prevent damage to the wearing surface of the wheels. (see illustration)

Operation

8.3 Saw blade replacement/tension



Warning!

Be wary of sharp edges to avoid cutting yourself, in particular when changing the tooling.

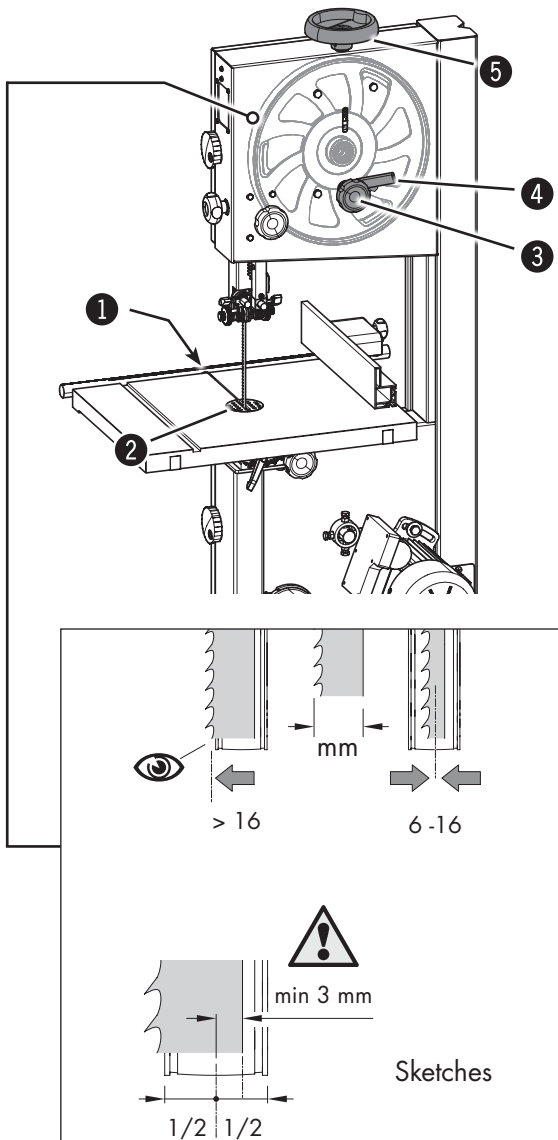

1. Disconnect the machine from the mains supply.
2. Remove table insert and positioning pin. Open wheel door.
3. Move the upper and lower saw band guide away from the saw blade.
4. Loosen the belt tensioning handwheel by turning it counterclockwise. Unthread old blade through the machine table.
5. Place new saw blade over both wheels (note the direction of the cut!).
6. Check the saw blade tension and if required, adjust with the hand wheel. The correct tension is displayed on the belt tension display, the displayed value has to correspond to the belt width.
7. Release the clamping lever and set the saw blade track using the hand wheel: **see sketches**



Attention!

The saw band run should only be adjusted with the hand wheel on the upper wheel. If the belt run cannot be adjusted with the upper wheel, an adjustment must be made on the lower wheel. See chapter entitled 8.3.1

8. Turn the wheels manually and ensure that the saw belt glides properly around the wheels and does not collide with any solid machine parts.
9. Clamp the clamping lever.
10. Adjust the upper and lower saw band guides to the new saw blade.
11. Install the safety equipment according to the instructions and check that it functions properly. Loosen the belt tensioning handwheel by turning it counterclockwise.

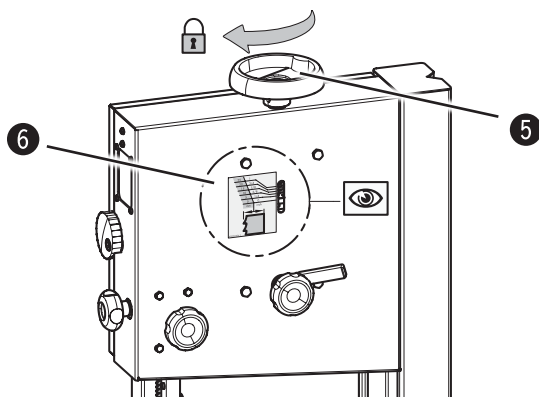

- ① Positioning pin
- ② Table insert
- ③ Handwheel - Saw blade track
- ④ Clamping lever
- ⑤ Blade tension hand wheel
- ⑥ Scale - saw belt tension

Fig. 8-3: Saw blade replacement

Operation

8.3.1 Setting - Saw blade track / Lower wheel

**Attention! Risk of material damage!**

The saw band run should only be adjusted with the hand wheel on the upper wheel.

If the belt run cannot be adjusted with the upper wheel, an adjustment must be made on the lower wheel.

Only the vertical adjusting screws for adjusting the lower wheel can be changed.

Proceed very cautiously with the settings described here.

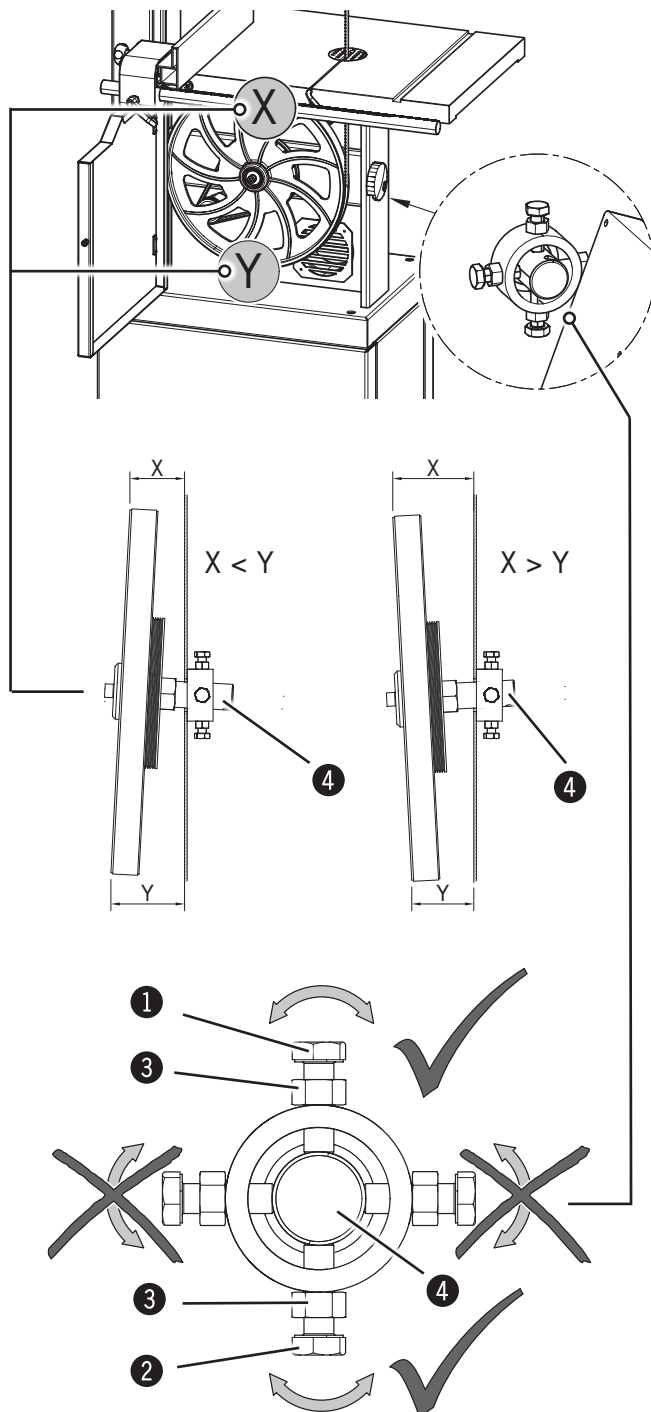

Measure the distance Y and X (from the front edge of the wheel to the machine frame). The values X and Y must be equal.

Setting - at $X > Y$:

Loosen the lock nuts.

Turn set screw 2 counterclockwise.

Turn set screw 1 clockwise until the pin is fixed.

Tighten the lock nuts.

Turn the wheels manually and ensure that the saw belt glides properly around the wheels and does not collide with any solid machine parts.

If necessary, readjust the upper wheel.

Check the setting and readjust if necessary.

Setting - at $X < Y$:

Loosen the lock nuts.

Turn set screw 1 counterclockwise.

Turn set screw 2 clockwise until the pin is fixed.

Tighten the lock nuts.

Turn the wheels manually and ensure that the saw belt glides properly around the wheels and does not collide with any solid machine parts.

If necessary, readjust the upper wheel.

Check the setting and readjust if necessary.

① setscrew 1 (Vertical)

② setscrew 2 (Vertical)

③ Locking nut

④ Pin

Fig. 8-4: Setting - Saw blade track/ Lower wheel

Operation

8.4 Tilting the table

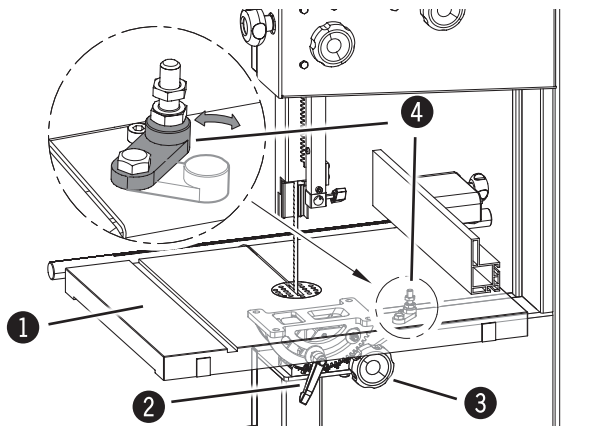

Fig. 8-5: Tilt

- ① Work bench
- ② Clamping lever
- ③ Lever
- ④ Fence - 0°

The machine working table can be tilted up to an angle from -5° up to $+45^\circ$

Adjusting the angle:

1. To tilt, remove the table padding to enable the saw belt to move through the table unimpeded.
2. Open the clamping screw with the supplied spanner and tilt the table to the desired angle, which is displayed on the mitre scale.
3. Tighten the clamping screw again.

Tilt -5° :

1. Swing away the stop
2. Adjusting the angle
3. To tilt the table back to its normal position, loosen the clamping screw once again and tilt the table up to the stop in the 0° position and clamp it in that position.
(Swing back the stop)

8.5 Adjusting the saw blade guide



Warning! Risk of injury!
Do not change settings whilst the machine is in operation!

8.5.1 Height adjustable protection device

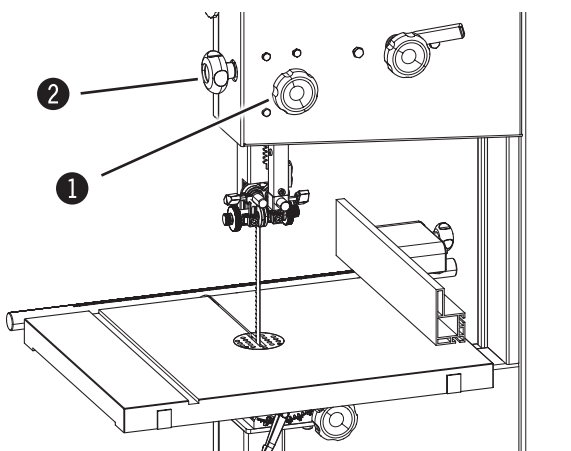

Fig. 8-6: Bearings

The upper saw blade guide has to be lowered as closely as possible to the work-piece (5–10 mm). To set the height, open the clamping screw and turn the hand wheel until the desired height has been reached. Tighten the clamping screw once again.

- ① Clamping screws
- ② Blade guide height adjustment

Operation

8.5.2 Saw blade guide - upper

! Attention! Risk of material damage!

The saw band guides can only be adjusted after the band tension and band run have been set correctly. The saw band guides must be readjusted after each saw band change.

Make the following settings precisely to prevent possible ignition sparks.

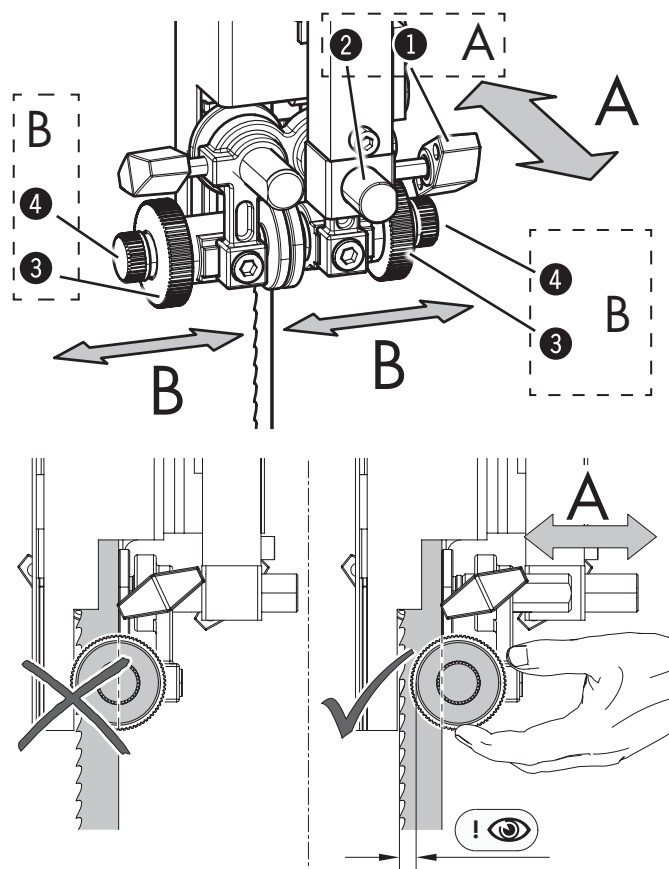

Fig. 8-7: Setting the side guiding elements

Setting the side guiding elements

direction A

Loosen the clamping screw.

Move the saw band guide on the adjusting pin.

The side guides must be positioned behind the main teeth of the saw blade, and even when cutting, must not be able to come in contact with the teeth.

Tighten the clamping screw.

direction B

Loosen the thumb nut.

Adjust the distance with the adjusting screw.

The side guide rollers should touch the saw blade slightly so as to obtain a straight and vibration-free cut.

Secure the thumb nut.

- ① Clamping screw
- ② Sliding link pins
- ③ Thumb nut
- ④ setscrew

Setting the rear guides

Loosen the clamping screw.

Move the back guide.

Adjust the back guide parallel to the saw band back with a small distance.

Tighten the clamping screw.

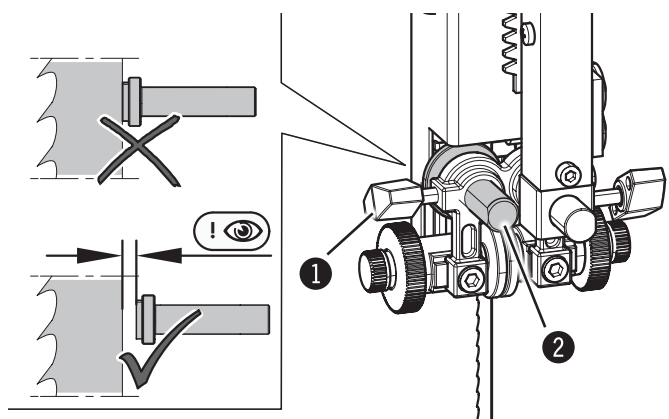

Fig. 8-8: Setting the rear guides

- ① Clamping screw
- ② back guide

Operation

8.5.3 Saw blade guide - down (Option)

! Attention! Risk of material damage!

The saw band guides can only be adjusted after the band tension and band run have been set correctly. The saw band guides must be readjusted after each saw band change.

Make the following settings precisely to prevent possible ignition sparks.

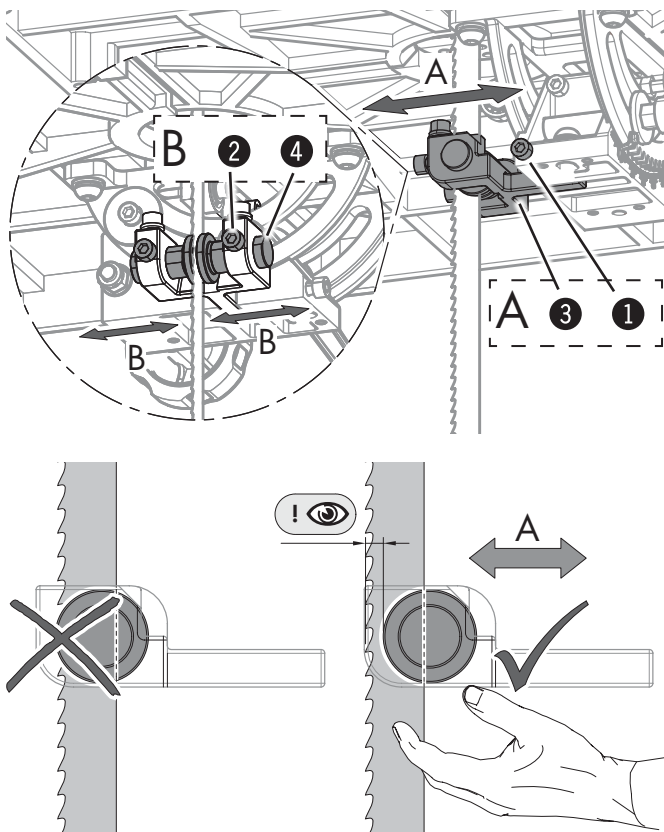

Fig. 8-9: Setting the side guiding elements

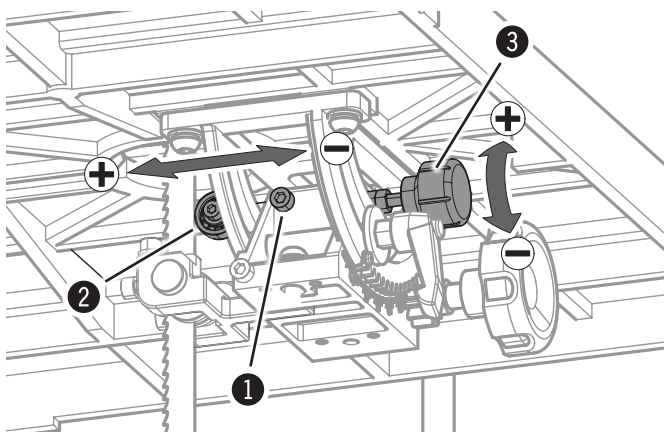

Fig. 8-10: Setting the rear guides

Setting the side guiding elements

direction A

Loosen the clamping screw 1.

Displace the guide part over the guide rod.

The side guides must be positioned behind the main teeth of the saw blade, and even when cutting, must not be able to come in contact with the teeth.

Clamp the clamping screw 1.

direction B

Loosen the clamping screw 2.

Slide the lateral guide on the adjusting bolt.

The side guide rollers should touch the saw blade slightly so as to obtain a straight and vibration-free cut.

Clamp the clamping screw 2.

- ① Clamping screw 1
- ② Clamping screw 2
- ③ Guide piece
- ④ Sliding link pins

Setting the rear guides

Loosen the clamping screw.

Adjust the back guide with the set screw.

Adjust the back guide parallel to the saw band back with a small distance.

Tighten the clamping screw.

- ① Clamping screw
- ② back guide
- ③ setscrew

Operation

8.6 Switching on the machine / Switching off the machine



Warning! Risk of injury due to insufficient preparation!

It is only permitted to switch on the machine if, for the work at hand, the required preconditions are fulfilled and any preliminary work is completed. Therefore, the adjusting, fitting and operating instructions (see the corresponding chapters) must be read before switching on the machine.



Attention! The machine will not start with the doors open and will automatically stop if doors are opened during operation. (Only valid for the CE-version !)

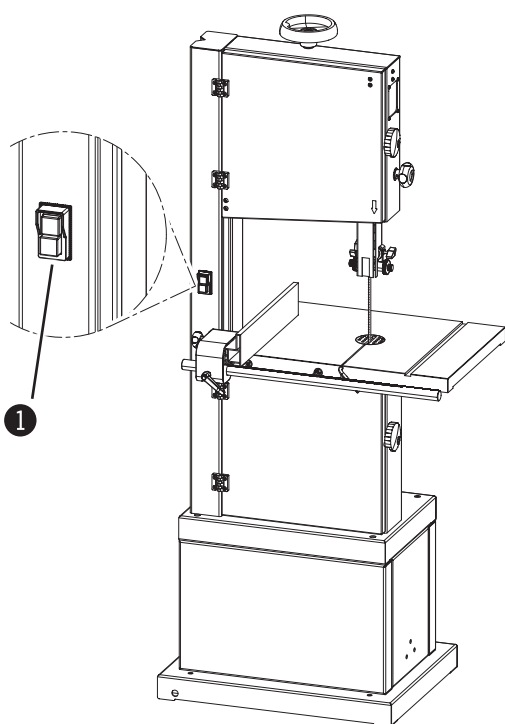

The bandsaw has an On- and Off switch.

Green push button:
Switch machine on

Red push button:
Switch off the machine.

① On/Off switch

Fig. 8-13: On- and Off switch

8.7 Authorised working techniques

8.7.1 Longitudinal cut along the marked line

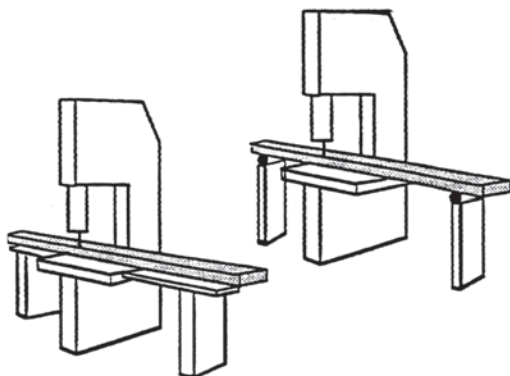

Fig. 8-14: Rip cut

All uses which differ from the following work techniques have not been intended for this machine and are therefore not authorised.

Feed the workpiece with constant speed and pressure forwards without applying sideways pressure. Do not interrupt the cut and do not pull the workpiece backwards. When cutting large pieces, use appropriate table extensions or roll supports.

Operation

8.7.2 Cutting round workpieces in the transverse direction

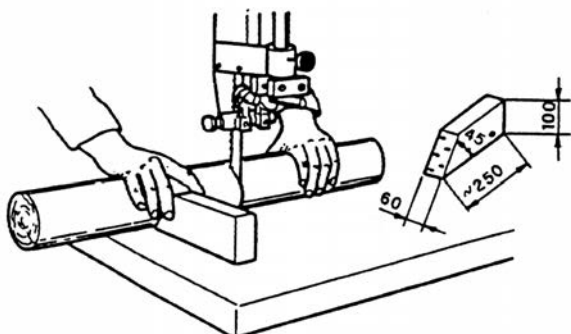

Use an appropriate device with the minimum measurements as depicted in Fig. to avoid the workpiece twisting during the cutting process.

Fig. 8-15: Cutting a circular workpiece

8.7.3 Cutting workpieces on the upright edge

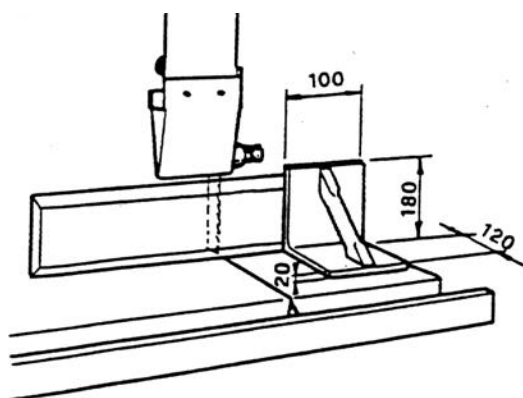

Use an auxiliary fence with the minimum measurements to guide the workpiece safely.

Fig. 8-16: Auxiliary fence

8.7.4 Longitudinal cut of narrow or thin workpieces with the longitudinal guide fence

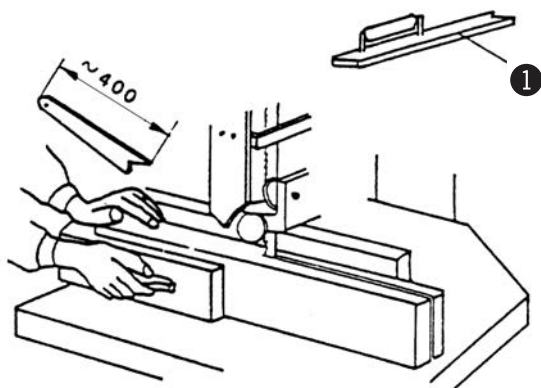

Use a push stick as depicted in Fig. to prevent your hands from coming too close to the saw blade.

① Push stick

Fig. 8-17: Push stick

Operation

8.7.5 Mitre cuts

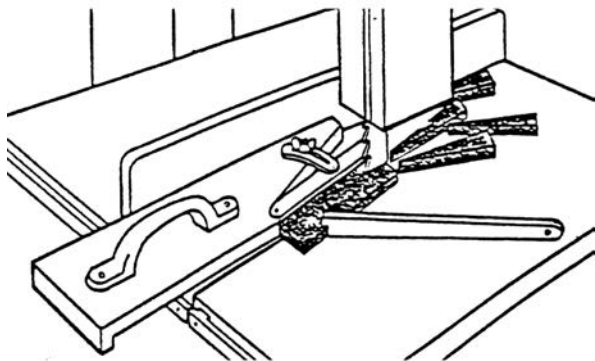

Fig. 8-18: Mitre cuts

Use auxiliary equipment as depicted in the figure.

8.7.6 Circular cuts

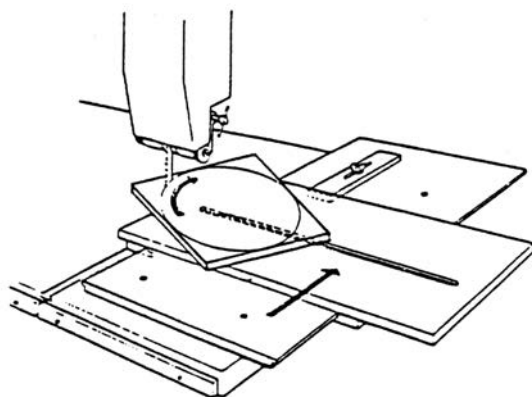

Fig. 8-19: Circular cuts

Use auxiliary equipment as depicted in the figure.

Accessories Order no.:
01.1.300

8.7.7 Diagonal cross-cut of rectangular workpieces

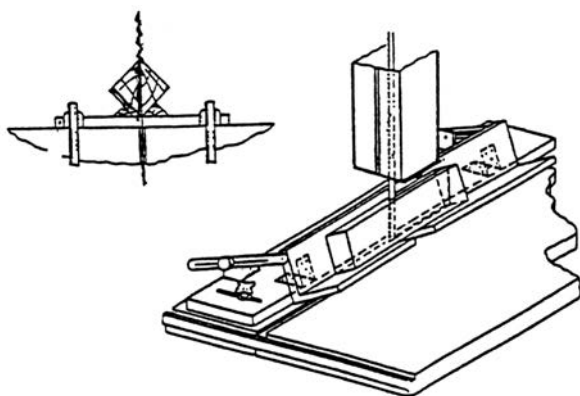

Fig. 8-20: Cross cut

Use auxiliary equipment as depicted in the figure.

Faults

9 Service

9.1 Safety instructions



Warning! Risk of injury!: Improper adjustment and setup work can lead to serious physical injury or material damage. For this reason, this work may only be carried out by authorised, trained personnel who are familiar with how to operate the machine and in strict observance of all safety instructions.

- Before beginning any maintenance work on the machine, switch it off and secure it against accidentally being switched on again.
- Before commencing any work with the machine, inspect it to ensure that it is complete and in technically good condition.
- Ensure that there is sufficient space to work around the machine.
- Keep the work area orderly and clean. Components and tools that are not put in their correct place or put away may be the cause of accidents!
- Install the safety equipment according to the instructions and check that it functions properly.



Warning! Danger! Electric current!: Work on electrical fittings may only be carried out by qualified personnel and in strict observance of the safety instructions.

9.2 Tightening/replacing the drive belt

Over time, the drive belt will lose its capacity to transmit power. At this point, the drive belt must be re-tensioned or replaced.

The drive belt must be inspected monthly; if tears are discovered, the drive belt must be replaced.

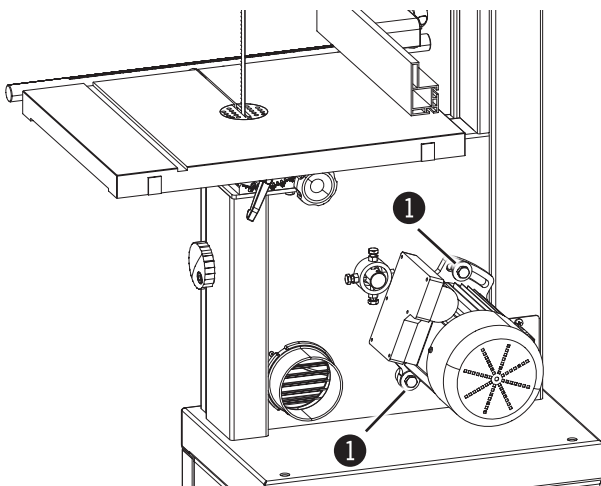

Fig. 9-1: Drive belts

1 Nut

Following the first few operating hours, the belt tension has to be controlled, as the belt will extend.

To check the tension, press inwards onto the belt in the middle with a weight of 3-4 kg. The belt deflection should not be more than 5-6 mm.

Retensioning the drive belt:

1. Loosen the nuts.
2. The motor must be swivelled to tension the drive belt.
3. Tighten the nuts.

It is important to always maintain the correct belt tension, as belts which are too loose will weaken the drive power and the brake power and belts which are overtightened will lead to overheating.



Attention! Risk of material damage!: Do not over-tension the drive belt!. Tighten the motor only until sufficient power transmission is ensured.

Faults

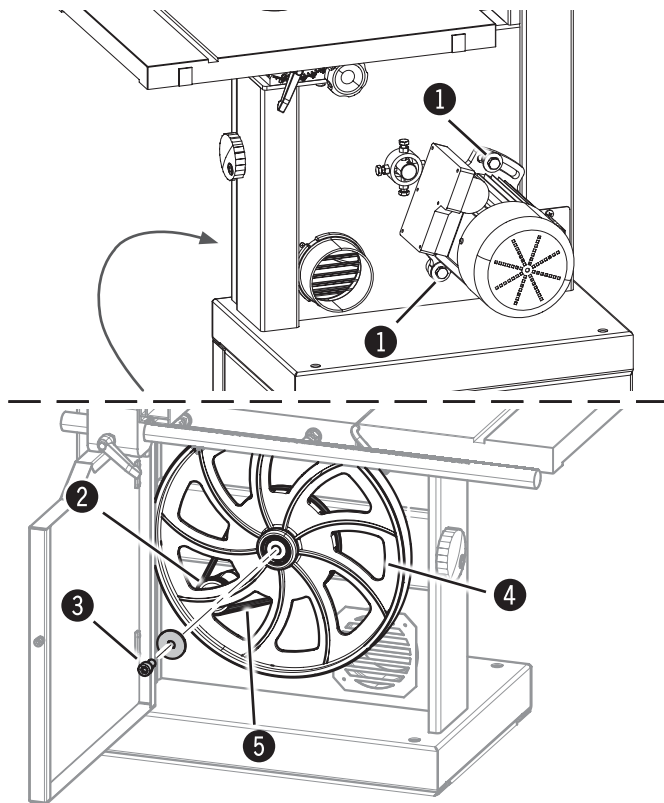

Fig. 9-2: Replace the drive belt.

Replace the drive belt. :

Removing the saw blade See chapter entitled: Saw blade replacement/tension

1. Open the locking nut until the v-belt moves slightly away from the drive pulley.
2. Loosen the clamping screw.
Disassembling the lower wheel.

Control: Defect or soiled wheel running surfaces

3. Place the new drive belt on the wheel.
Slide the wheel onto the shaft.
Tighten the clamping screw.
5. Attach the belt to the motor pulley.
Ensure that the belt is seated properly with a few manual turns!
6. Retensioning the drive belt

- ① Nut
- ② Motor pulley
- ③ Clamping screw
- ④ Lower wheel
- ⑤ Drive belt



Attention! Risk of material damage!:

Check the rubber surface of the wheels regularly for damage. In case of excessive wear, the wheels must be replaced.

9.3 Upper wheel - Replace

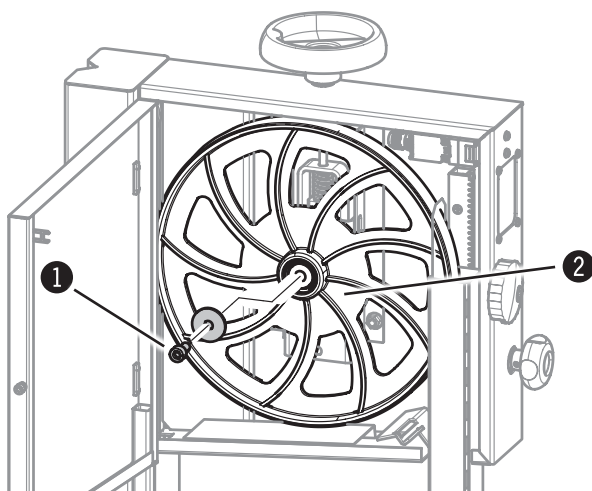

Fig. 9-3: Disassembling the upper wheel

Removing the saw blade See chapter entitled: Saw blade replacement/tension

1. Loosen the clamping screw.
2. Disassembling the upper wheel
3. Slide the wheel onto the shaft.
4. Tighten the clamping screw.

- ① Clamping screw
- ② Upper wheel

Faults

9.4 Cleaning and lubrication

Clean the inside of the machine regularly with a vacuum to remove saw dust deposits and remove resin deposits from the wheel surfaces. The wheel bearings are sealed and do not need to be lubricated again.

The following components are to be lubricated:

- Adjustment - saw belt tension
- Gearbox - Height adjustable protection device
- Tilttable table

Regularly control the cleanliness of the wheel wearing

surfaces, especially after resinous materials or chipboards have been cut. Only clean the wearing surfaces once the machine is idle and ensure that the wearing surfaces are not damaged during the process.

9.4.1 Adjustment - saw belt tension

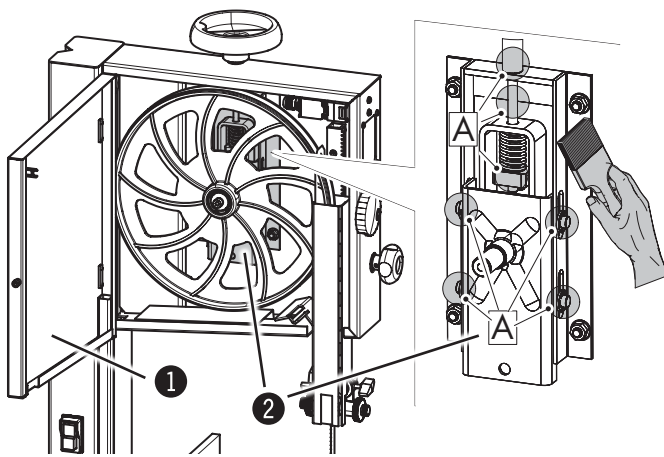

Fig. 9-4: Adjustment - saw belt tension

1. Before beginning any maintenance work on the machine, switch it off and secure it against accidentally being switched on again.
2. Open wheel door
Removing the saw blade See chapter entitled: Saw blade replacement/tension
3. In spots A:
Lubricate with regular machine grease.
4. Turn the belt tensioning handwheel all the way down and turn it all the way up again.
5. Installing the saw blade

- ① Wheel door
- ② Adjustment - saw belt tension
- ③ Blade tension hand wheel

9.4.2 Gearbox - Height adjustable protection device

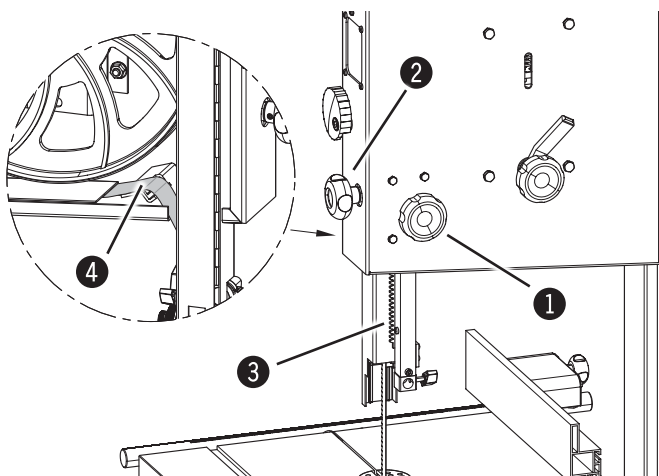

Fig. 9-5: Adjustment - saw belt tension

1. Before beginning any maintenance work on the machine, switch it off and secure it against accidentally being switched on again.
2. Loosen the clamping screw. Open wheel door. Turn the belt guide height adjustment all the way down (towards the working table).
3. Spray a thin layer of lubricant onto the gear rack after it has been cleaned. Clean the guard plate and apply a thin layer of machine grease.
4. Turn the belt guide height adjustment all the upper end again.
5. Close the door. Clamp the clamping screw.

- ① Clamping screw
- ② Blade guide height adjustment
- ③ Gear rack
- ④ Guard plate

Faults

9.4.3 Tilttable table

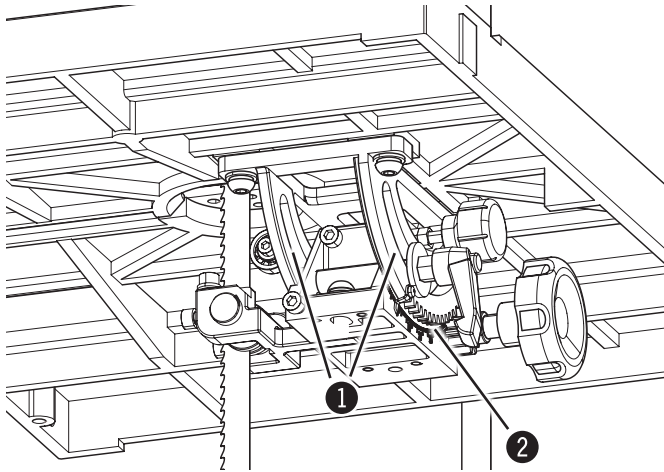

Fig. 9-6: Tilttable table

1. Before beginning any maintenance work on the machine, switch it off and secure it against accidentally being switched on again.
2. Lubricate the guides and gear unit with normal machine grease. Check if functioning.

- ① Guide
- ② Gearbox

9.5 Direction of cut and parallelism

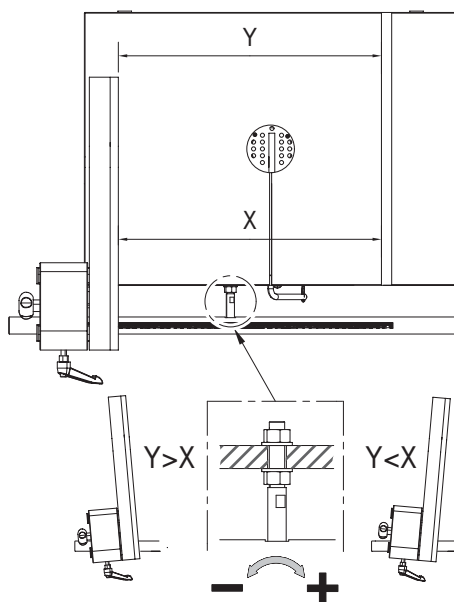

Fig. 9-7: Direction of cut and parallelism

If the cut, using the longitudinal stop, is still not parallel, the following are possible causes:

- Incorrect saw belt grinding and set
- Insufficient saw belt tension
- Incorrect longitudinal stop setting in relation to the saw belt.

Setting the rip fence - See chapter entitled 7.2.4

Faults

10 Faults

10.1 Safety instructions



Warning! Risk of injury!: Repairing faults incorrectly can result in personal injury or damage to the machine. For this reason, this work may only be carried out by authorised, trained personnel who are familiar with how to operate the machine and in strict observance of all safety instructions.



Warning! Danger! Electric current!: Work on electrical fittings may only be carried out by qualified personnel and in strict observance of the safety instructions.

10.2 What to do if a fault develops

In most cases:

- In the event of a breakdown which creates danger for either personnel or equipment, the machine should be stopped immediately by activating the emergency stop.
- Also disconnect the machine from the mains and ensure it can not be switched on again.
- Inform those responsible for machine faults immediately.
- Type and extent of fault should be determined by an authorised professional, as well as the cause and repair.

10.3 What to do after rectifying the fault



Warning! Risk of injury!

Before switching the machine back on:

- The fault and its cause are professionally repaired.,
- All safety equipment has been assembled according to regulations and is working correctly.,
- Individuals are not located within the danger area of the machine.

Faults

10.4 Faults, causes and repairs

Fault	Cause and problem elimination
Machine does not start	Safety break switches are breaking the electric circuit ⇒ Ensure that the side doors are closed properly
	Emergency stop switch engaged ⇒ Unlock the emergency stop switch
Squeaking noises when starting up	Insufficient tension (Drive belt) ⇒ Retensioning the drive belt
The cuts are not straight	Check sharpness and set of saw blade
	Check the guide fence alignment
The saw blade is torn at the base of the individual teeth	Incorrect sharpness and constant overheating, or otherwise incorrect set of saw blade
	Width of saw blade is too thick in relation to the diameter of the wheel
	Defect or soiled wheel running surfaces
	Incorrectly aligned wheels Contact customer service
The saw blade is rupturing on the rear side	Feed rate or pressure is too high during cutting
	Poor welded joint ⇒ Saw blade replacement
	The rear support roller of the saw blade guide is defective
The machine comes to a stillstand with the saw belt locked into the workpiece	Immediately switch off the machine. Enlarge the cutting gap with a wedge and remove the workpiece. Prior to switching the machine on again, check the condition of the saw belt and its position on the wheels.
The saw belt is straying forwards and backwards	The belt is not aligned with the welded joints ⇒ Saw blade replacement
The saw blade is slipping to the back at the beginning of the cut	The saw blade is not sharp enough or is unsuitable for the type of material to be cut, or the surface of the wheel is defective

Hammer®

FELDER KG

KR-Felder-Straße 1, 6060 Hall in Tirol, AUSTRIA



+43 (0) 5223 / 58 50 0



+43 (0) 5223 / 56 13 0

info@felder-group.com

www.felder-group.com